

Version : 1.2

TECHNICAL SPECIFICATION
MODEL NO. : PA040XS1

Customer's Confirmation

Customer _____

By _____

PVI's Confirmation

Dep	FAE	Panel Design	Electronic Design	Mechanical Design	Product Verification	Prepared by
Sign	劉豐發 9/9/05	李明 9/11/05	金聖坤 9/11/05	林育生 9/9/05	潘天 9/11/05	楊泉 9/10/05

TECHNICAL SPECIFICATION***CONTENTS***

<i>NO.</i>	<i>ITEM</i>	<i>PAGE</i>
-	Cover	1
-	Contents	2
1	Application	3
2	Features	3
3	Mechanical Specifications	3
4	Mechanical Drawing of TFT-LCD module	4
5	Input / Output Terminals	5
6	Pixel Arrangement	6
7	Absolute Maximum Ratings	7
8	Electrical Characteristics	7
9	Power On Sequence	17
10	Optical Characteristics	17
11	Handling Cautions	21
12	Reliability Test	22
13	Block Diagram	23
14	Packing	24
-	Revision History	26

1. Application

This technical specification applies to 4" color TFT-LCD module , PA040XS1.

The applications of the panel are car TV, portable DVD, GPS, door phone, multimedia applications and others AV system..

2. Features

.Amorphous silicon TFT-LCD panel with B/L unit.

. Compatible with NTSC & PAL system

. Pixel in stripe configuration

. Slim and compact

. Image Reversion : Up/Down and Left/Right
(With PVI timing controller : PVI-1004D)

3. Mechanical Specifications

Parameter	Specifications	Unit
Screen Size	4 (diagonal)	inch
Display Format	320×(R,G,B)×234	dot
Active Area	81.12(H)× 61.78(V)	mm
Pixel Pitch	0.2535(H)× 0.264 (V)	mm
Pixel Configuration	Stripe	
Outline Dimension	96(W)× 75.98(H)× 6.2(D)(typ.)	mm
Surface Treatment	Anti – Glare	
Weight	74±5	g
Display mode	Normally white	

4. Mechanical Drawing of TFT-LCD Module

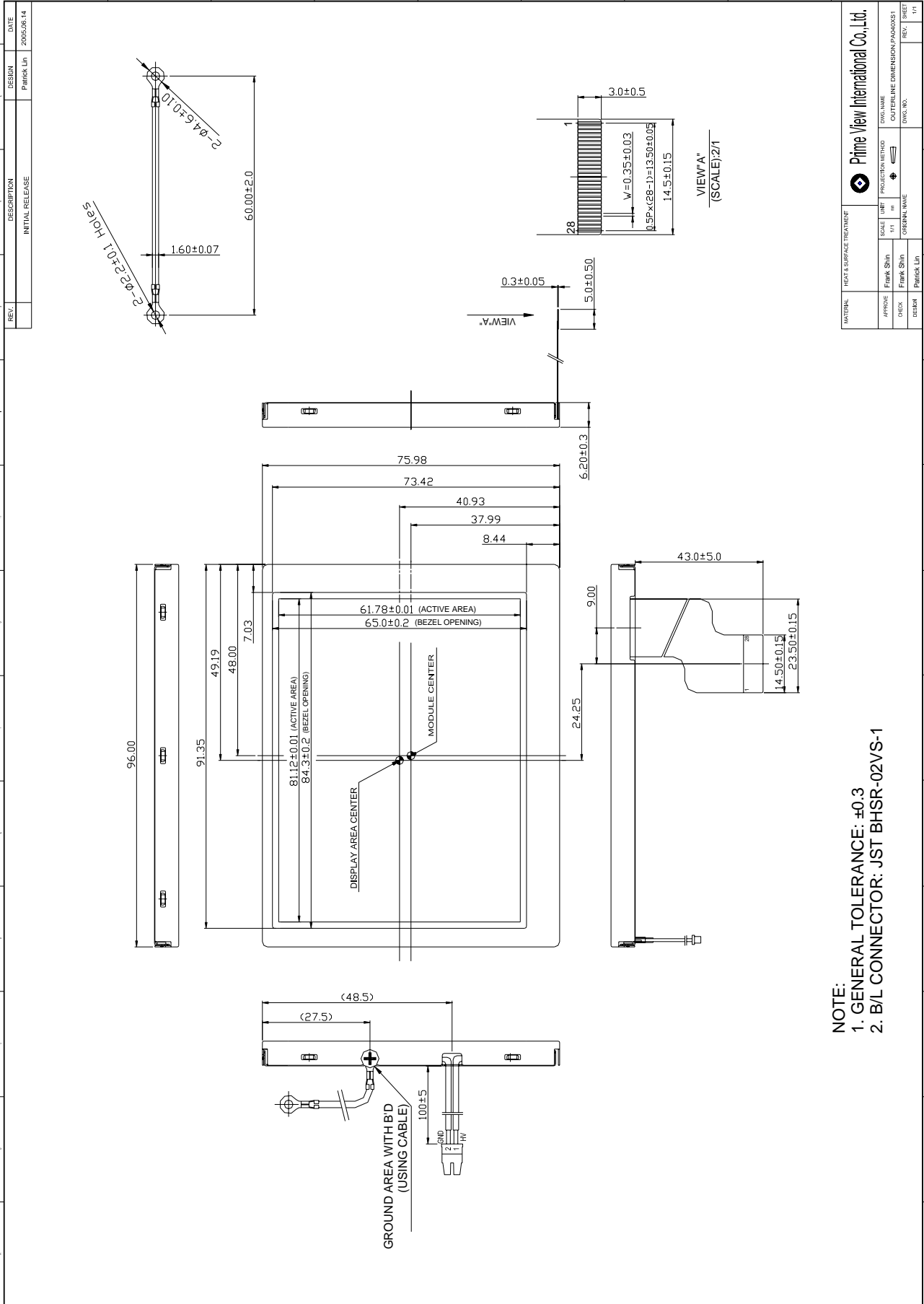

NOTE:
 1. GENERAL TOLERANCE: ±0.3
 2. B/L CONNECTOR: JST BHSR-02VS-1

PRIME VIEW INTERNATIONAL CO., LTD.		SCALE: 1/1		PRODUCTION METHOD: 1/1		DWG. NAME: PA040XS1	
APPROVE: Frank Shin	DRAWN: Frank Shin	CHECK: Frank Shin	DESIGN: Patrick Lin	DATE: 2005.06.14	DESIGNER: Patrick Lin	DATE: 2005.06.14	REVISION: 1/1

5. Input / Output Terminals

TFT-LCD Module Connector

FPC Down Connect , 28Pins , Pitch : 0.5 mm

Pin No	Symbol	I/O	Description	Remark
1	STH1	I/O	Start pulse for source driver	Note 5-1
2	AV _{SS}	I	Analog GND for source driver	
3	AV _{DD}	I	Analog power input for source driver	Note 5-3
4	V _B	I	Video Input B	
5	V _G	I	Video Input G	
6	V _R	I	Video Input R	
7	V _{SS}	I	Digital GND	
8	V _{DD}	I	Digital power input	Note 5-4
9	CPH1	I	Sampling and shift clock for source driver	
10	CPH2	I	Sampling and shift clock for source driver	
11	CPH3	I	Sampling and shift clock for source driver	
12	STH2	I/O	Start pulse for source driver	Note 5-1
13	N/C	-	Not connector	
14	OE	I	Output enable for source driver	
15	R/L	I	Left/Right Control for source driver	Note 5-1
16	V _{COM}	I	Common electrode voltage	Note 5-5
17	V _{COM}	I	Common electrode voltage	
18	XOE	I	Output enable for gate driver	
19	CPV	I	Clock input for gate driver	
20	U/D	I	Up/Down Control for gate driver	Note 5-2
21	STVU	I/O	Vertical start pulse	
22	STVD	I/O	Vertical start pulse	
23	V _{GL}	I	Gate off voltage(alternative every 1-H)	Note 5-6
24	N/C	-	Not connector	
25	V _{SS}	I	GND	
26	V _{CC}	I	Logic power for gate driver	Note 5-4
27	V _{GH}	I	Gate on voltage	Note 5-7
28	GND	-	B/L case GND	

Note 5-1

R/L	STH1	STH2	scanning direction
V _{CC}	input	output	left to right
GND	output	input	right to left

Note 5-2

U/D	STVD	STVU	scanning direction
Vcc	input	output	down to up
GND	output	input	up to down

The definitions of Note 5-1,5-2

U/D(PIN 20)=Low R/L(PIN 15)=High

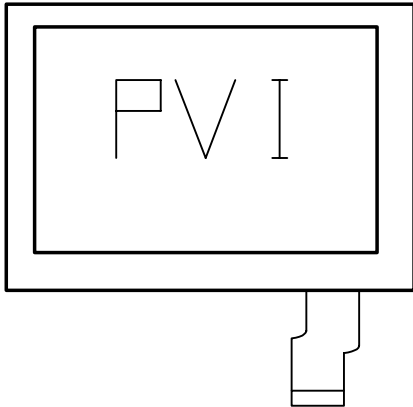

U/D(PIN 20)=High R/L(PIN 15)=Low

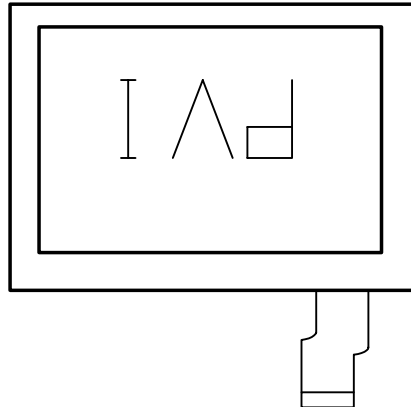

Note 5-3 : $AV_{DD} = +5V$ (Typ.)

Note 5-4 : $V_{DD}, V_{CC} = +3.3$ (Typ.)

Note 5-5 : $V_{COM} = 6V_{PP}$.

Note 5-6 : $V_{GL} = -12V$ (Typ.).

Note 5-7 : $V_{GH} = +17V$ (Typ.).

6. Pixel Arrangement

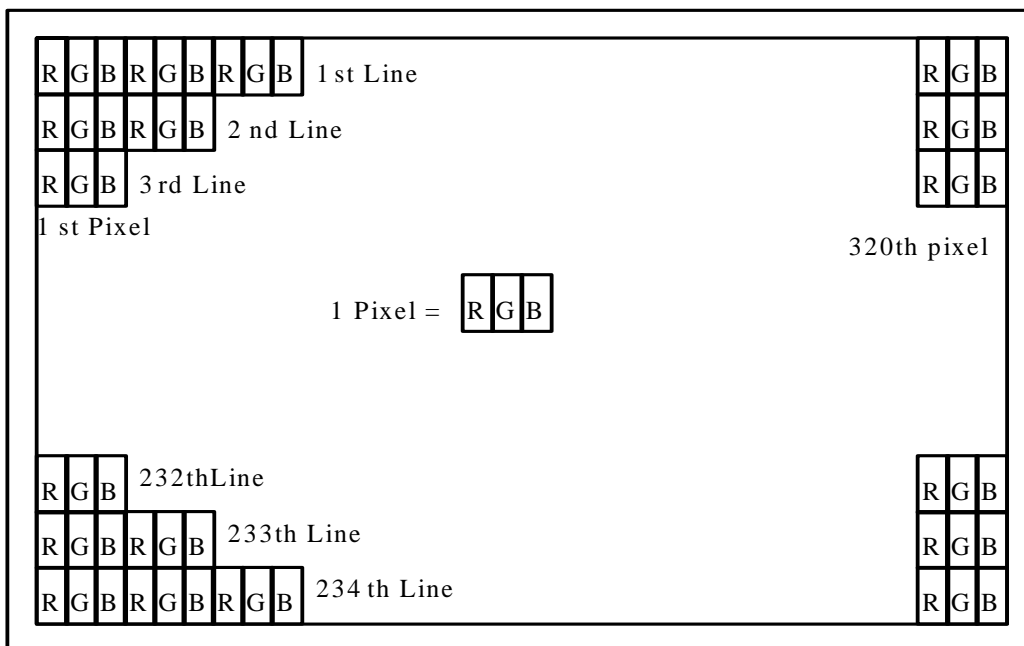

7. Absolute Maximum Ratings :

The followings are maximum values, which if exceeded, may cause faulty operation or damage to the unit.

$$GND = 0 V, T_a = 25$$

Parameter	Symbol	MIN.	MAX.	Unit	Remark
Supply Voltage For Source Driver	AV_{DD}	-0.3	+5.8	V	
	V_{DD}	-0.3	+7.0	V	
Supply Voltage For Gate Driver	V_{CC}	-0.3	+7.0	V	
	$V_{GH}-V_{GL}$	-0.3	+45.0	V	
	H Level V_{GH}	-0.3	+32.0	V	
	L Level V_{GL}	-22	+0.3	V	
Operation Temperature		-20	+70		
Storage Temperature		-30	+80		

8. Electrical Characteristics
8-1) Operating Condition

Parameter		Symbol	MIN.	Typ.	MAX.	Unit	Remark
Supply Voltage For Source Driver	Analog	AV_{DD}	+4.5	+5.0	+5.5	V	
	Logic	V_{DD}	+3.0	+3.3	+3.6	V	Depend on T/C signal voltage
Supply Voltage For Gate Driver	H level	V_{GH}	+15	+17	+19	V	
	L level	$V_{GL DC}$	-13	-12	-10.5	V	DC Component of V_{GL}
		$V_{GL AC}$	-	+6.0	-	V_{P-P}	AC Component of V_{GL}
	Logic	V_{CC}	+3.0	+3.3	+3.6	V	Depend on T/C signal voltage
		+4.5	+5.0	+5.5	V		
Video Signal (V_R, V_G, V_B)		$V_i AC$	-	+4.0		V_{P-P}	AC Component
		$V_i DC$	-	+2.5	-	V	DC Component
Digital input voltage	H level	V_{IH}	$0.7 V_{DD}$	-	V_{DD}	V	
	L level	V_{IL}	0	-	$0.3 V_{DD}$	V	
Digital output voltage	H level	V_{OH}	$V_{DD}-0.4$	-	V_{DD}	V	
	L level	V_{OL}	0	-	0.4	V	
V_{COM}		$V_{COM AC}$	-	+6.0	-	V_{P-P}	AC Component of V_{COM}
		$V_{COM DC}$		1.5		V	DC Component of V_{COM} Note 8 -1

Note 8-1 : PVI strongly suggests that the $V_{COM DC}$ level shall be adjustable , and the adjustable level range is $1.5V \pm 1V$, every module's $V_{COM DC}$ level shall be carefully adjusted to show a best image performance.

8-2) Recommended driving condition for back light:

Parameter	Symbol	Min.	Typ.	Max.	Unit	Remark
Lamp voltage	V_L	285	316	348	V _{rms}	$I_L=5mA$
Lamp current	I_L	2.0	5.0	5.5	mA	
Lamp frequency	P_L	20	38	60	KHz	Note 8-3 $I_L=5mA$
Kick-off voltage(25 °)	V_s			840	V _{rms}	Note 8-4
Kick-off voltage(0 °)	V_s			930	V _{rms}	

Note 8-3 : In order to satisfy the quality of B/L , no matter use what kind of inverter , the output lamp current must between Min. and Max. to avoid the abnormal display image caused by B/L.

Note 8-4 : The waveform of lamp driving voltage should be as closed to a perfect SIN wave as possible.

Note 8-5 : he "Max of kick off voltage" means the minimum voltage of inverter to turn on the CCFL. and it should be applied to the lamp for more than 1 second to start up. Otherwise the lamp may not be turned on

Back Light Connector : JST BHSR-02VS-1, Pitch : 3.5 mm

Pin No	Symbol	Description	Remark
1	VL1	Input terminal (Hi voltage side)	
2	VL2	Input terminal (Low voltage side)	Note 8-6

Note 8-6 : Low voltage side of back light inverter connects with Ground of inverter circuit.

8-3) Current Consumption (GND=0V)
T_a= 25

Parameter	Symbol	Condition	Typ.	Max.	Unit	Remark
Supply current for Source Driver(Analog)	I_{AVDD}	$V_{DD}=+5V$	7.0	10.0	mA	
Supply current for Source Driver(Digital)	I_{VDD}	$V_{DD}=+3.3V$	1.2	3.0	mA	
Supply current for Gate Driver (Low level)	I_{GL}	$V_{GL}=-12V$	0.3	0.45	mA	V_{GL} center voltage
Supply current for Gate Driver (Digital)	I_{CC}	$V_{CC}=+3.3V$	0.03	0.05	mA	
Supply current for Gate Driver (Hi level)	I_{GH}	$V_{GH}=+17V$	0.2	0.5	mA	
LCD Panel Power Consumption			45	70	mW	Note 8-7
Back Light Lamp Power Consumption			1.58	1.725	W	Note 8-8 $I_L=5mA$
Total Power Consumption			1.625	1.795	W	

Note 8-7 : The power consumption for back light is not included.

Note 8-8 : Backlight lamp power consumption is calculated by $I_L \times V_L$.

8-4) Timing Characteristics Of Input Signals

Characteristics	Symbol	Min.	Typ.	Max.	Unit	Remark
Rising time	t_r	-	-	10	ns	
Falling time	t_f	-	-	10	ns	
High and low level pulse width	t_{CPH}	147	156	166	ns	CPH1
CPH pulse duty	t_{CWH}	30	50	70	%	CPH1
STH setup time	t_{SUH}	20	-	-	ns	STH1,STH2
STH hold time	t_{HDH}	20	-	-	ns	STH1,STH2
STH pulse width	t_{STH}	-	1	-	t_{CPH}	STH1,STH2
STH period	t_H	61.5	63.5	65.5	μs	STH1,STH2
OEH pulse width	t_{OEH}	-	1.6	-	μs	OEH
Sample and hold disable time	t_{DIS1}	-	4.4	-	μs	
OEV pulse width	t_{OEV}	-	12	-	μs	OEV
CKV pulse width	t_{CKV}	-	32	-	μs	CPV
Clean enable time	t_{DIS2}	-	6	-	μs	
Horizontal display timing range	t_{DH}	-	320	-	$t_{CPH}/3$	
STV setup time	t_{SUV}	400	-	-	ns	STVU,STVD
STV hold time	t_{HDV}	400	-	-	ns	STVU,STVD
STV pulse width	t_{STV}	-	-	1	t_H	
Horizontal lines per field	t_V	256	262	268	t_H	
Vertical display start	t_{SV}		3	-	t_H	
Vertical display timing range	t_{DV}		234	-	t_H	
VCOM rising time	t_{rCOM}		-	5	μs	
VCOM falling time	t_{fCOM}		-	5	μs	
VCOM delay time	t_{DCOM}		-	3	μs	
RGB delay time	t_{DRGB}		-	1	μs	

8-5) Signal Timing Waveforms

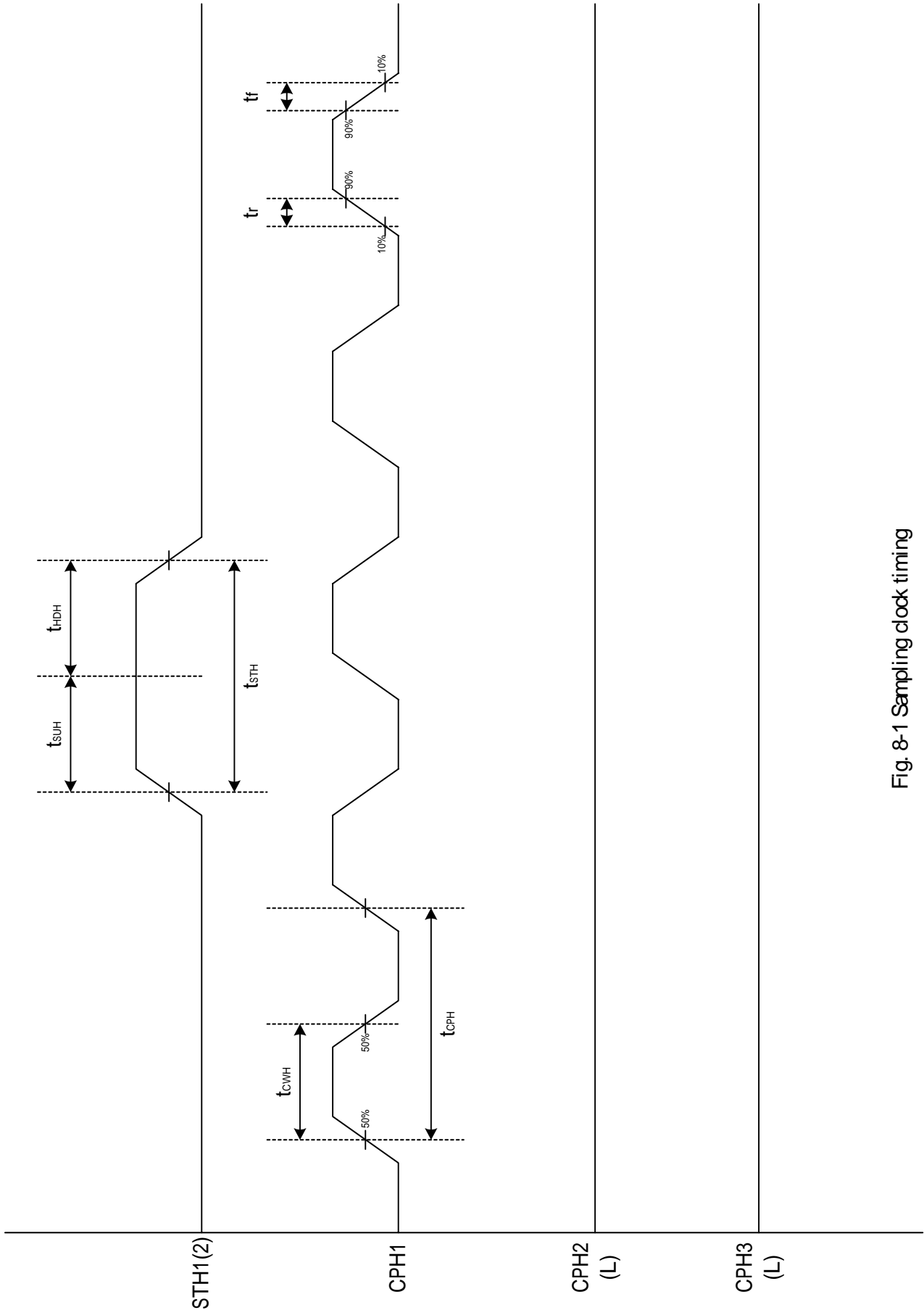

Fig. 8-1 Sampling clock timing

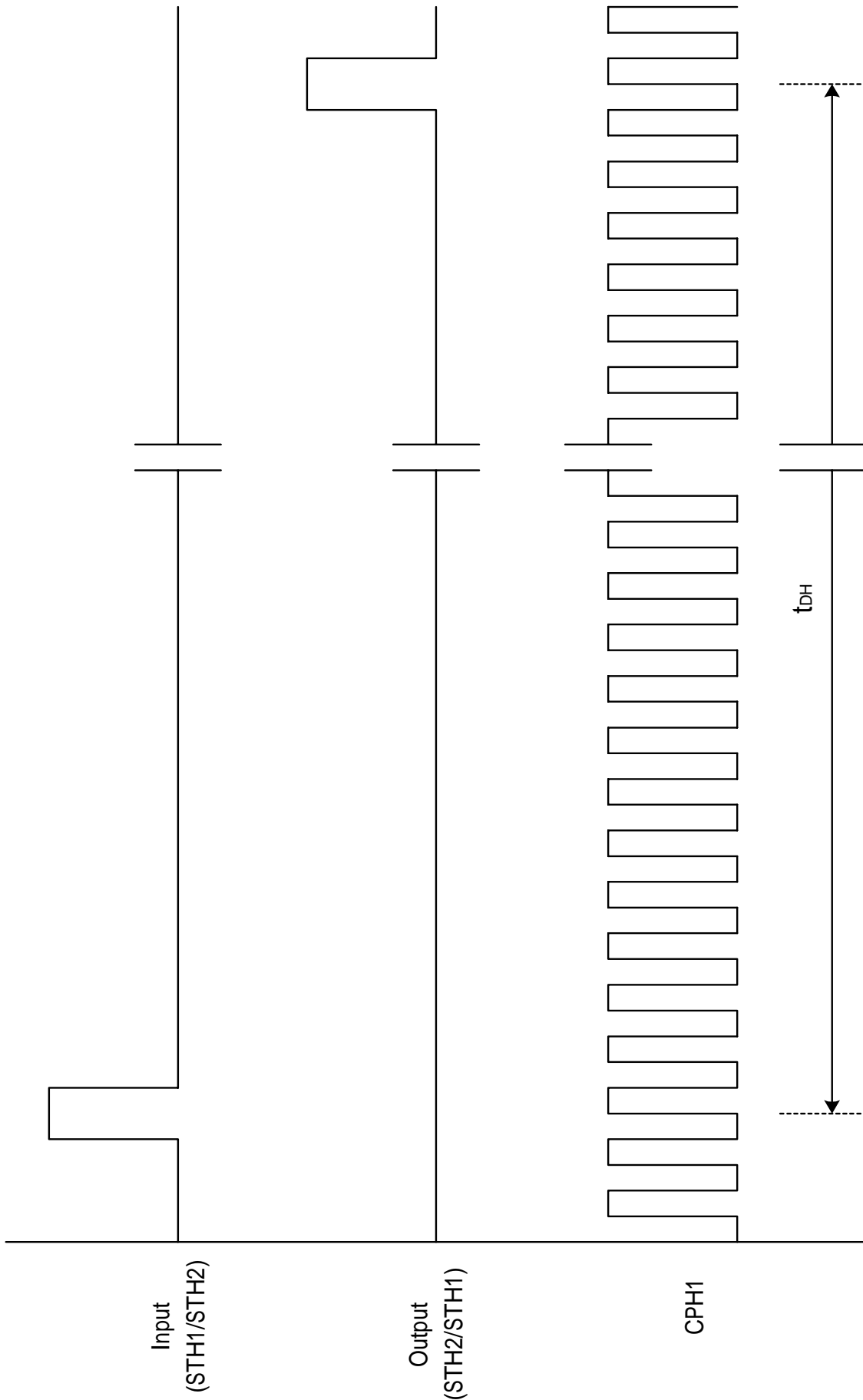

Fig. 8-2 Horizontal display timing range

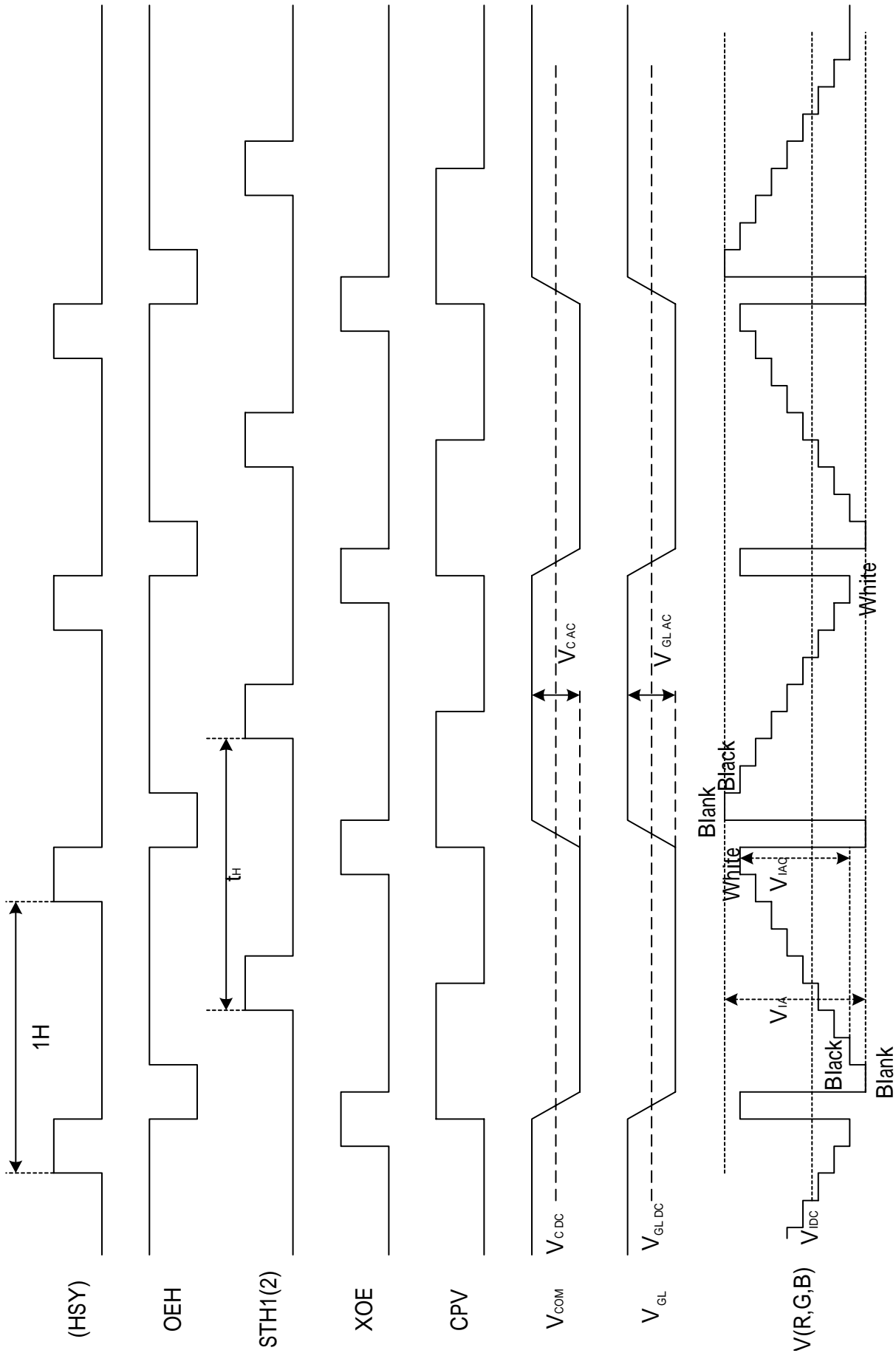
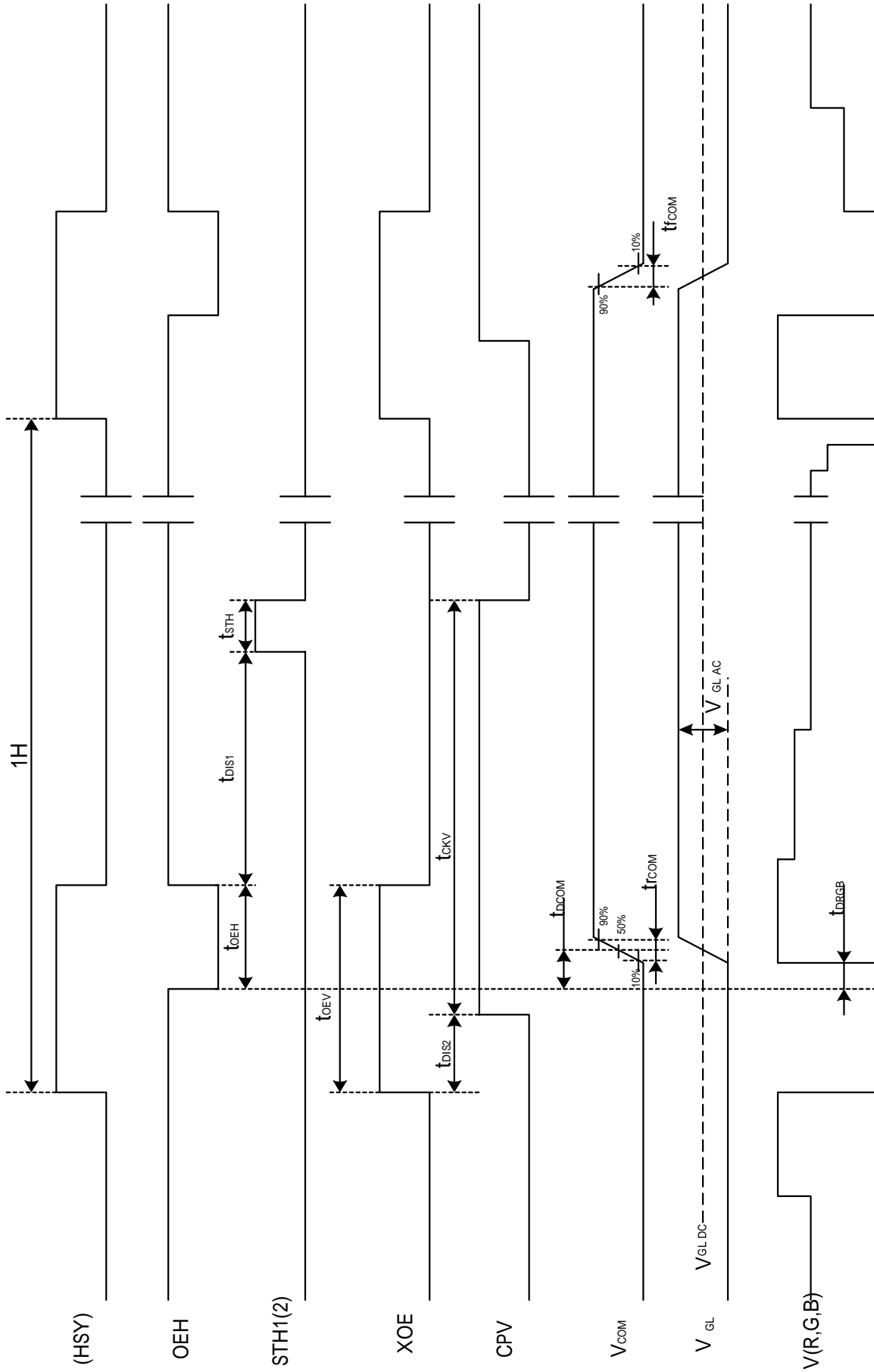

Fig. 8-3 (a) Horizontal timing



Note : The falling edge of OEV should be synchronized with the falling edge of OEH

Fig. 8-3 (b) Detail horizontal timing

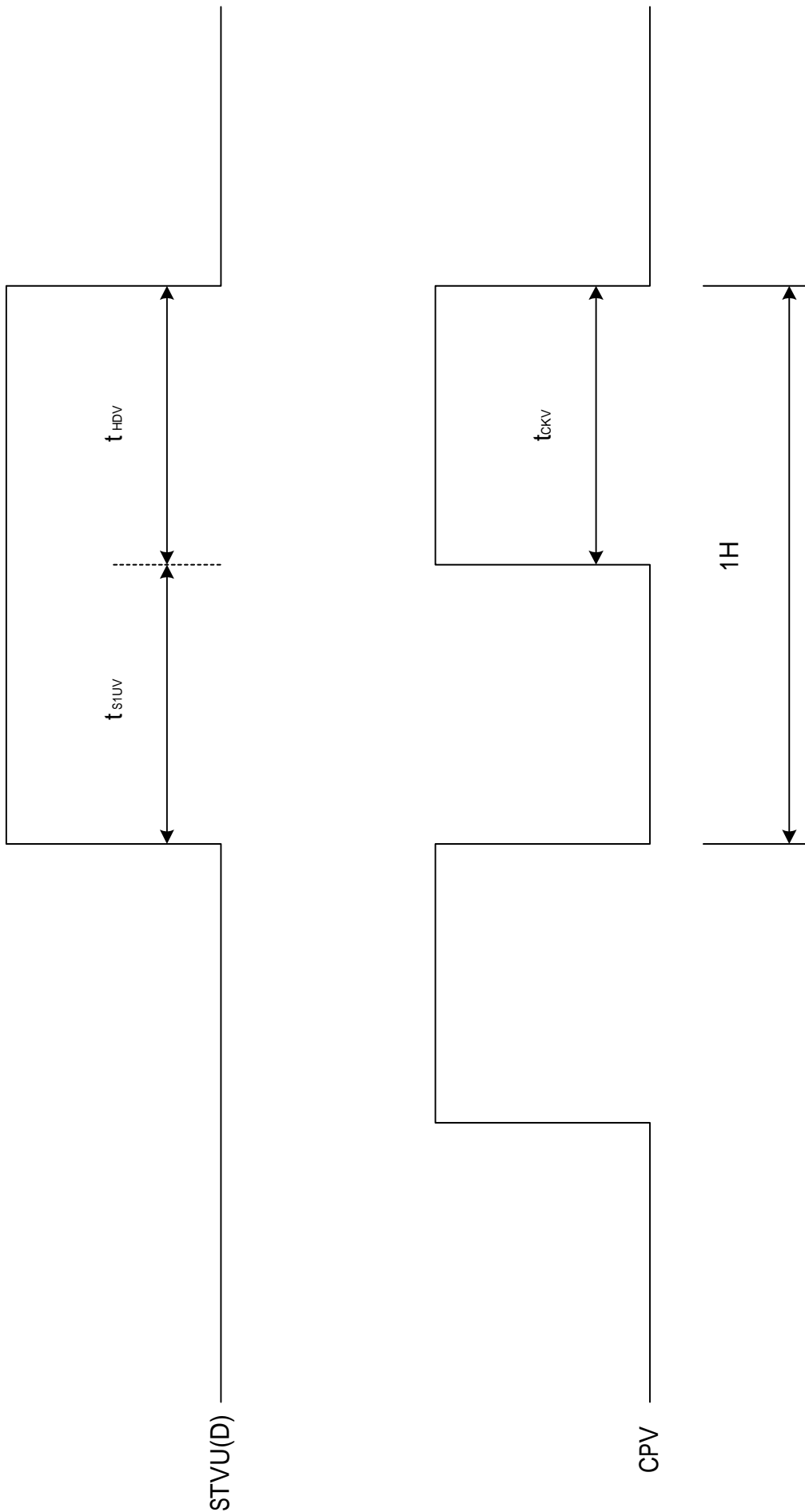

Fig. 8-4 Vertical shift clock timing

Vertical timing (From up to down)

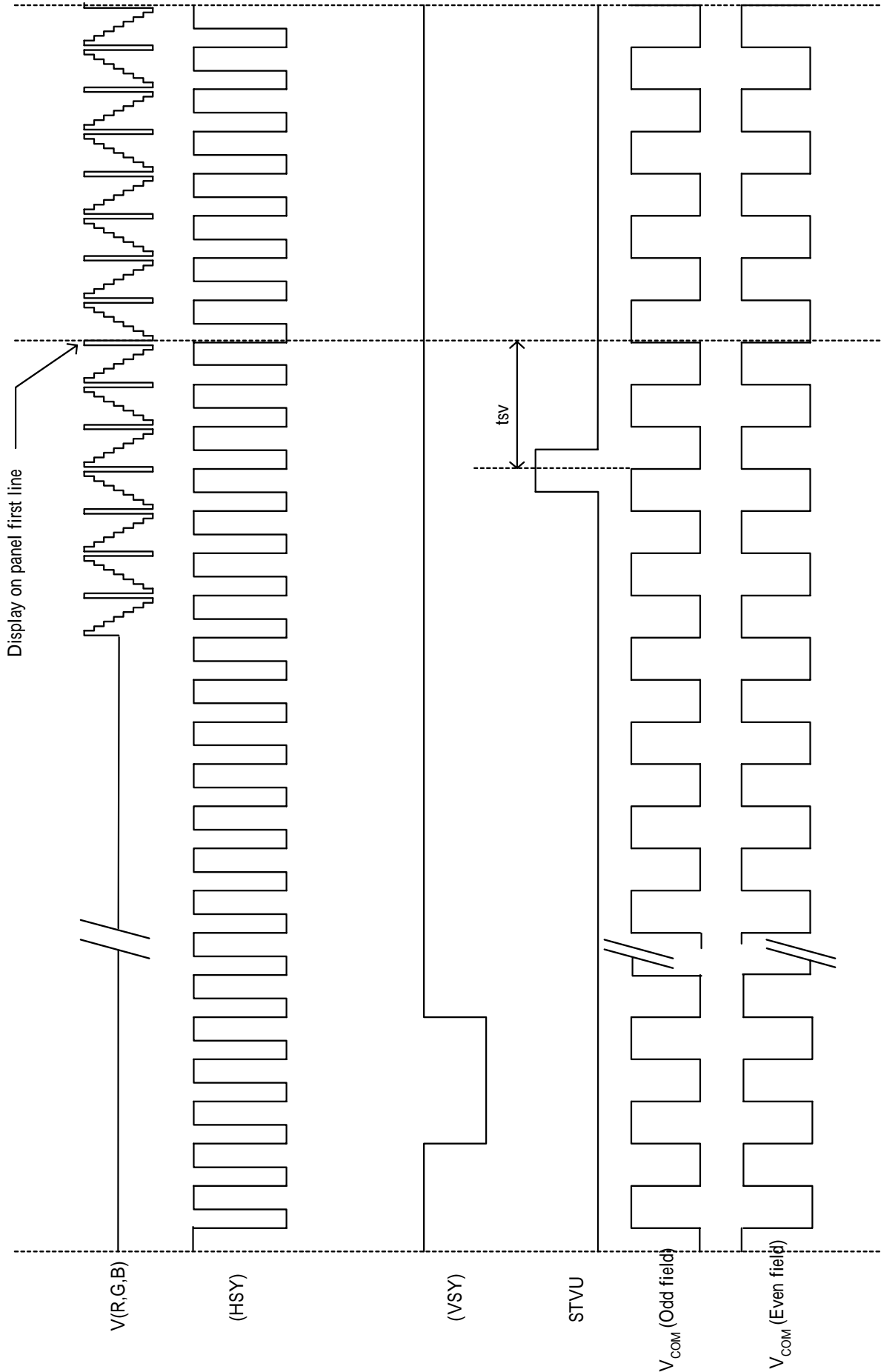

Fig. 8-5 (a) Vertical timing (From Up to Down)

Vertical timing (From down to up)

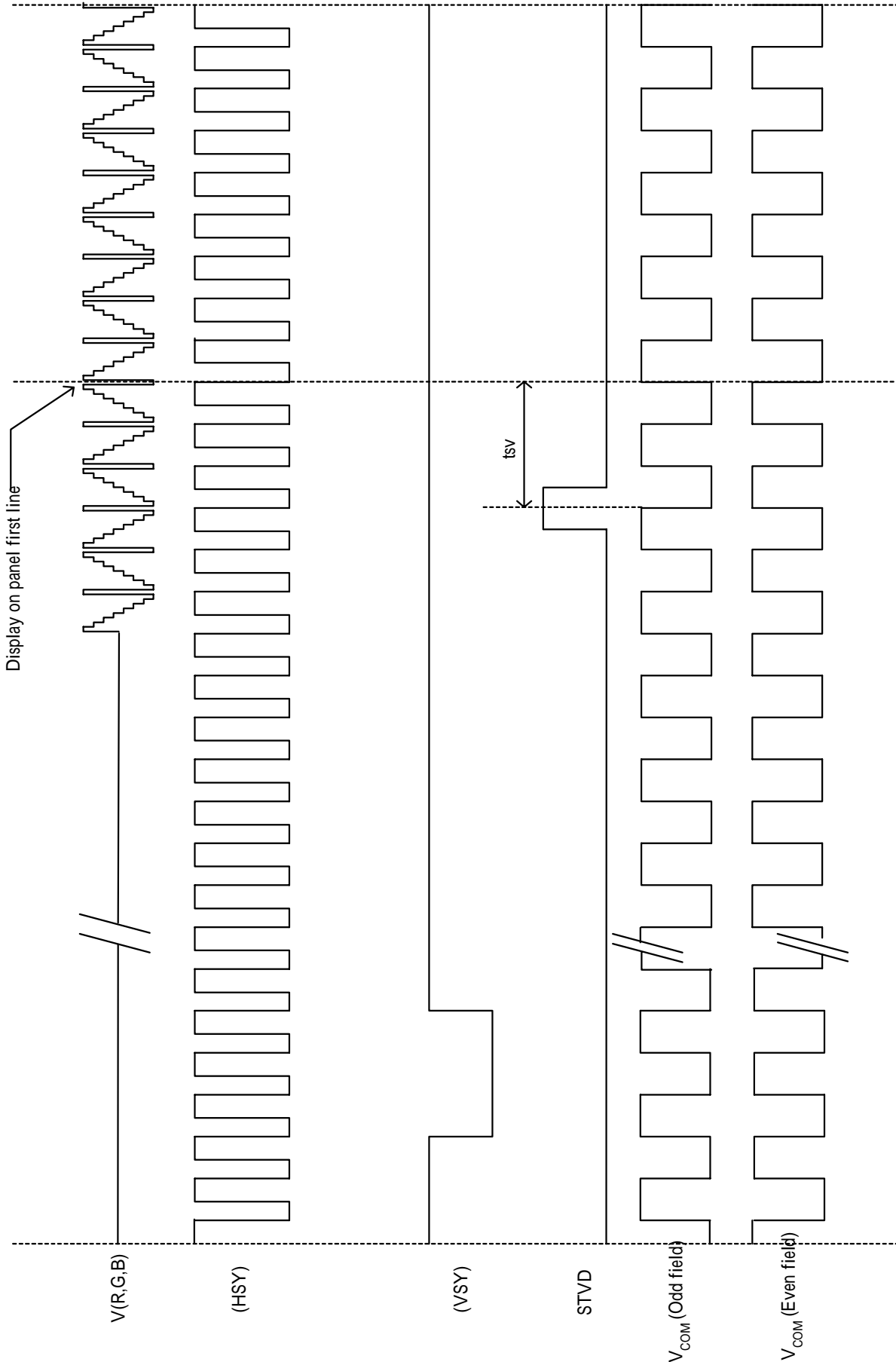
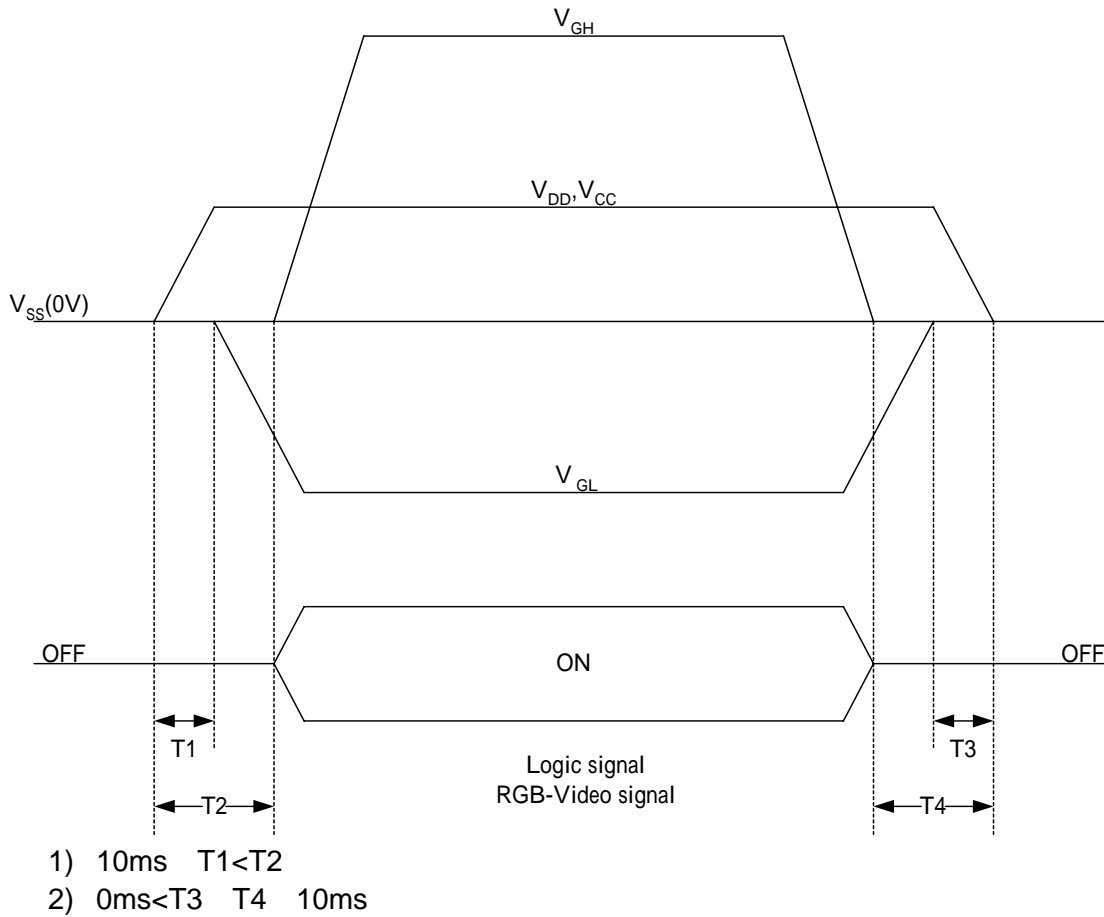

Fig. 8-5 (b) Vertical timing (From Down to Up)

9. Power On Sequence

The Power on Sequence only effect by V_{CC} , V_{SS} , V_{DD} , V_{GL} and V_{GH} , the others do not care.

10. Optical Characteristics
10-1) Specification:
 $T_a = 25$

Parameter	Symbol	Condition	MIN.	TYP.	MAX.	Unit	Remarks	
Viewing Angle	Horizontal	CR 10	45	50	---	deg	Note 10-1	
	Vertical		11	30	35	---		deg
			12	10	15	---		deg
Contrast Ratio	CR	At optimized Viewing angle	200	350	---	---	Note 10-2	
Response time	Rise	T_r	---	15	30	ms	Note 10-4	
	Fall	T_f	---	25	50	ms		
Uniformity	U	---	70	80	---	%	Note 10-5	
Brightness	---	Center point	300	350	---	cd/m^2	Note 10-3	
White	x	$=0^\circ$	0.28	0.31	0.34	---		
Chromaticity	y	$=0^\circ$	0.30	0.33	0.36	---		
Lamp Life Time	---	+25	---	10000	---	Hr	---	

Note 10-1 : The definitions of viewing angles

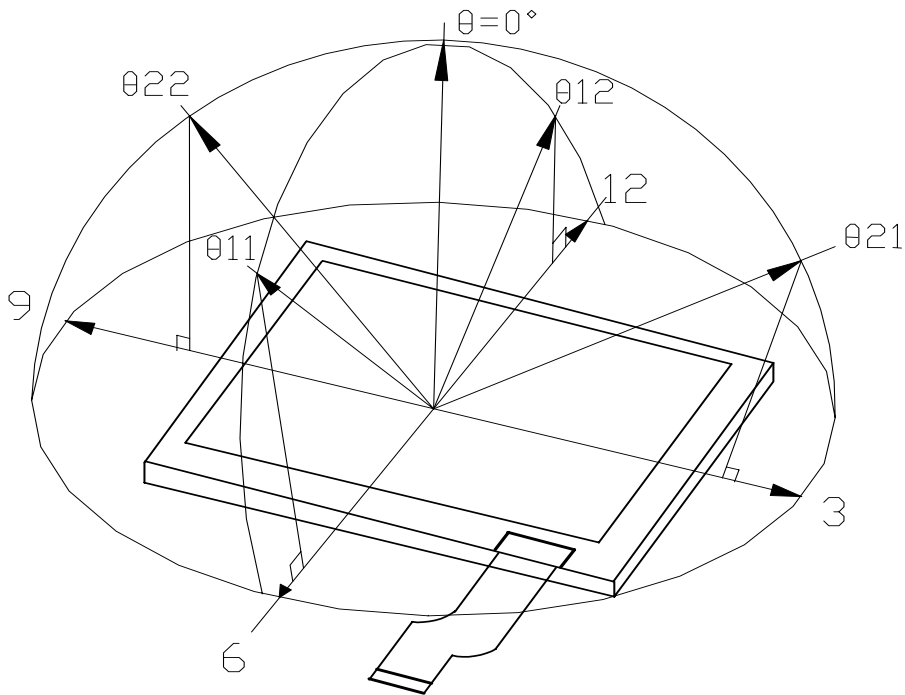

Note 10-2 : $CR = \frac{\text{Luminance when Testing point is White}}{\text{Luminance when Testing point is Black}}$
 (Testing configuration see 10-2)
 Contrast Ratio is measured in optimum common electrode voltage.

Note 10-3 : Topcon BM-7(fast) luminance meter 1°field of view is used in the testing (after 20~30 minutes operation).
 Lamp Current 5mA

Note 10-4 : The definition of response time :

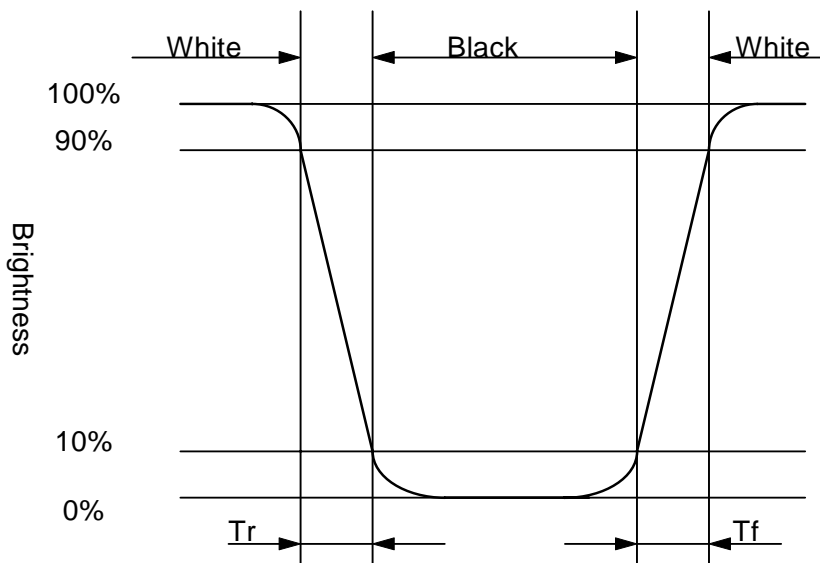

Note 10-5: The uniformity of LCD is defined as

$$U = \frac{\text{The Minimum Brightness of the 9 testing Points}}{\text{The Maximum Brightness of the 9 testing Points}}$$

Luminance meter : BM-5A or BM-7 fast(TOPCON)

Measurement distance : 500 mm +/- 50 mm

Ambient illumination : < 1 Lux

Measuring direction : Perpendicular to the surface of module

The test pattern is white (Gray Level 63).

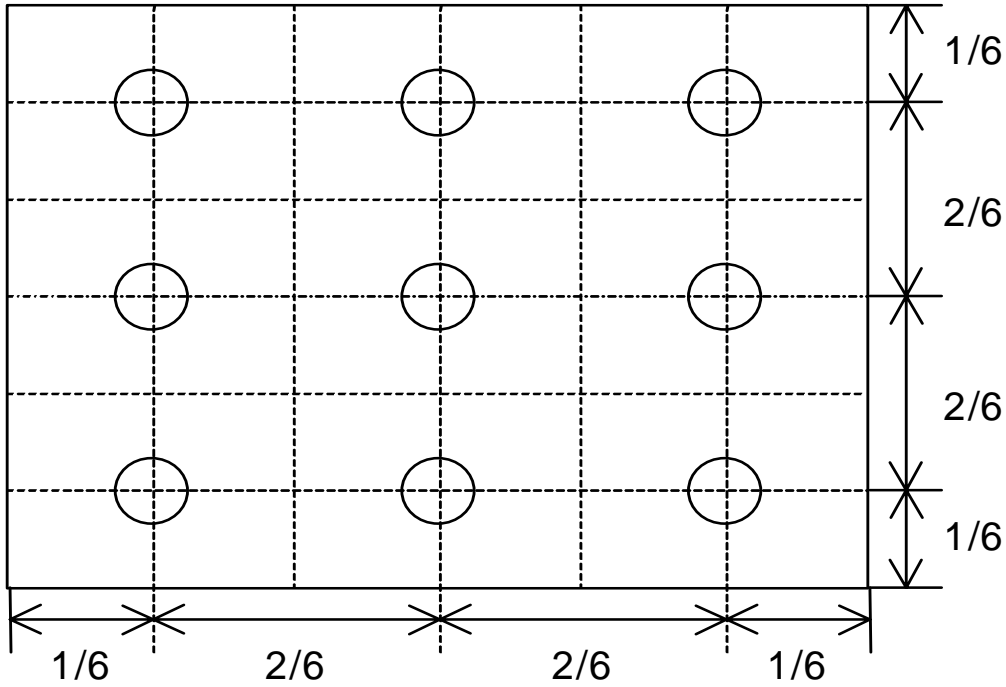

10-2) Testing configuration

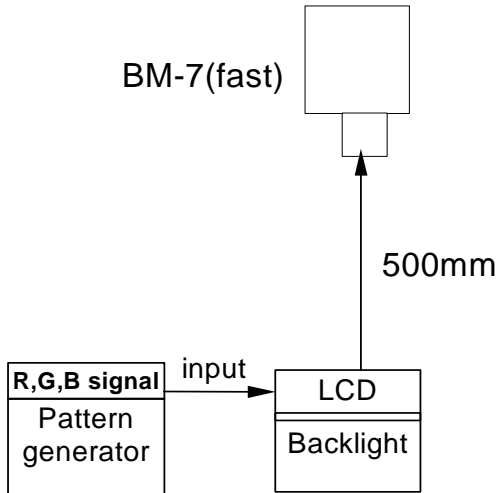

Caution: 1. Environmental illumination 1 lux
 2. Before test CR, Vcom voltage must be adjusted carefully to get the best CR.

- LCD Display

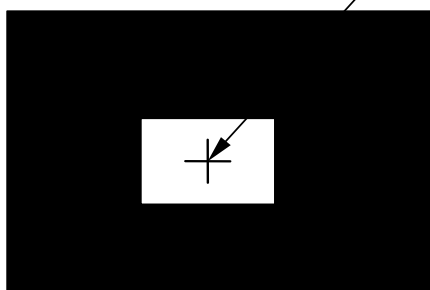

Pattern A

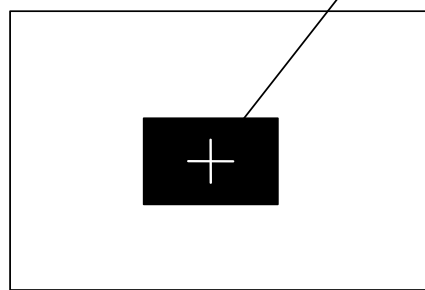

Pattern B

- R, G, B Waveform of Pattern A at Testing Point

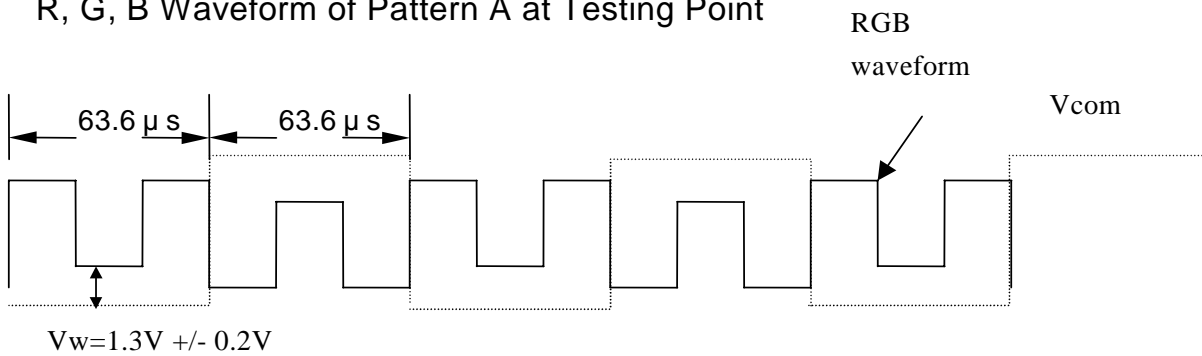

- R, G, B Waveform of Pattern B at Testing Point

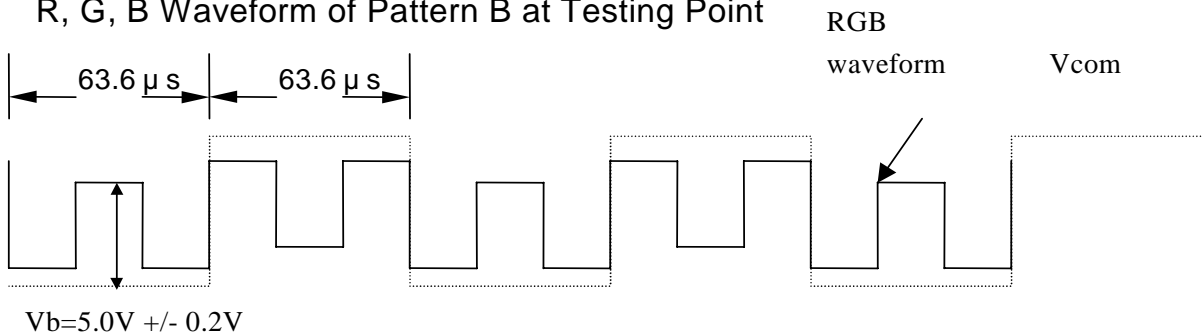

11. Handling Cautions

11-1) Mounting of module

- a) Please power off the module when you connect the input/output connector.
- b) Please connect the ground pattern of the inverter circuit surely. If the connection is not perfect, some following problems may happen possibly.
 1. The noise from the backlight unit will increase.
 2. The output from inverter circuit will be unstable.
 3. In some cases a part of module will heat.
- c) Polarizer which is made of soft material and susceptible to flaw must be handled carefully.
- d) Protective film (Laminator) is applied on surface to protect it against scratches and dirt. It is recommended to peel off the laminator before use and taking care of static electricity.

11-2) Precautions in mounting

- a) Wipe off water drops or finger grease immediately. Long contact with water may cause discoloration or spots.
- b) TFT-LCD module uses glass which breaks or cracks easily if dropped or bumped on hard surface. Please handle with care.
- c) Since CMOS LSI is used in the module. So take care of static electricity and earth yourself when handling.

11-3) Others

- a) Do not expose the module to direct sunlight or intensive ultraviolet rays for many hours.
- b) Store the module at a room temperature place.
- c) The voltage of beginning electric discharge may over the normal voltage because of leakage current from approach conductor by to draw lump read lead line around.
- d) If LCD panel breaks, it is possibly that the liquid crystal escapes from the panel. Avoid putting it into eyes or mouth. When liquid crystal sticks on hands, clothes or feet. Wash it out immediately with soap.
- e) Observe all other precautionary requirements in handling general electronic components.

12. Reliability Test

No	Test Item	Test Condition
1	High Temperature Storage Test	Ta = +80 , 240 hrs
2	Low Temperature Storage Test	Ta = -30 , 240 hrs
3	High Temperature Operation Test	Ta = +70 , 240 hrs
4	Low Temperature Operation Test	Ta = -20 , 240 hrs
5	High Temperature & High Humidity Operation Test	Ta = +60 , 90%RH, 240 hrs
6	Thermal Cycling Test (non-operating)	-20 +70 , 200 Cycles 30 min 30 min
7	Vibration Test (non-operating)	Frequency : 10 ~ 55 Hz Amplitude : 1.5 mm Sweep time: 11 mins Test Period : 6 Cycles for each direction of X, Y, Z
8	Shock Test (non-operating)	100G, 6ms Direction : ±X, ±Y, ±Z Cycle : 3 times
9	Electrostatic Discharge Test (non-operating)	200pF, 0 ±200V 1 time / each terminal

Ta: ambient temperature

Note : The protective film must be removed before temperature test.

[Criteria]

Under the display quality test conditions with normal operation state, there should be no change which may affect practical display function.

13. Block Diagram

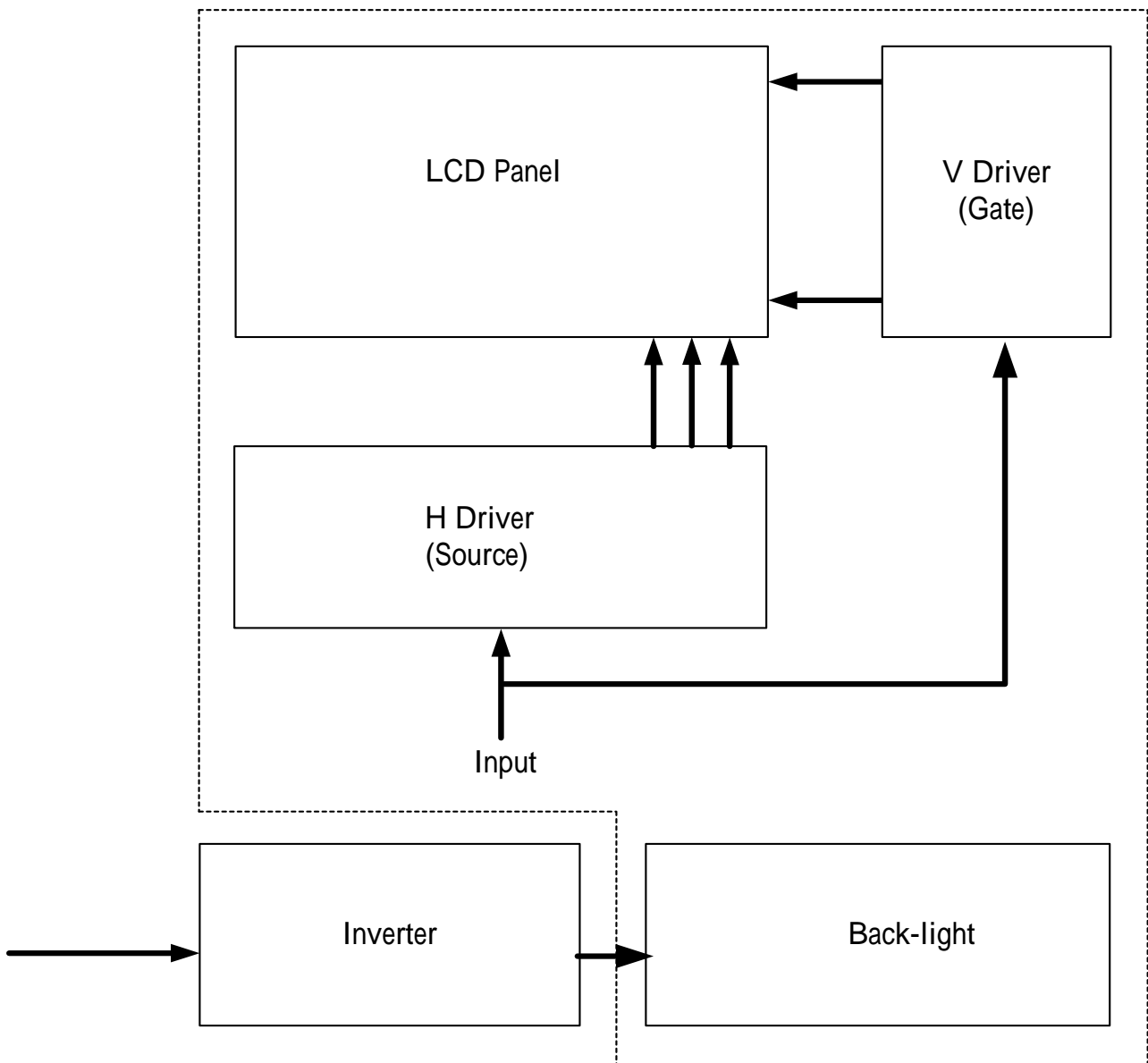

14. Packing

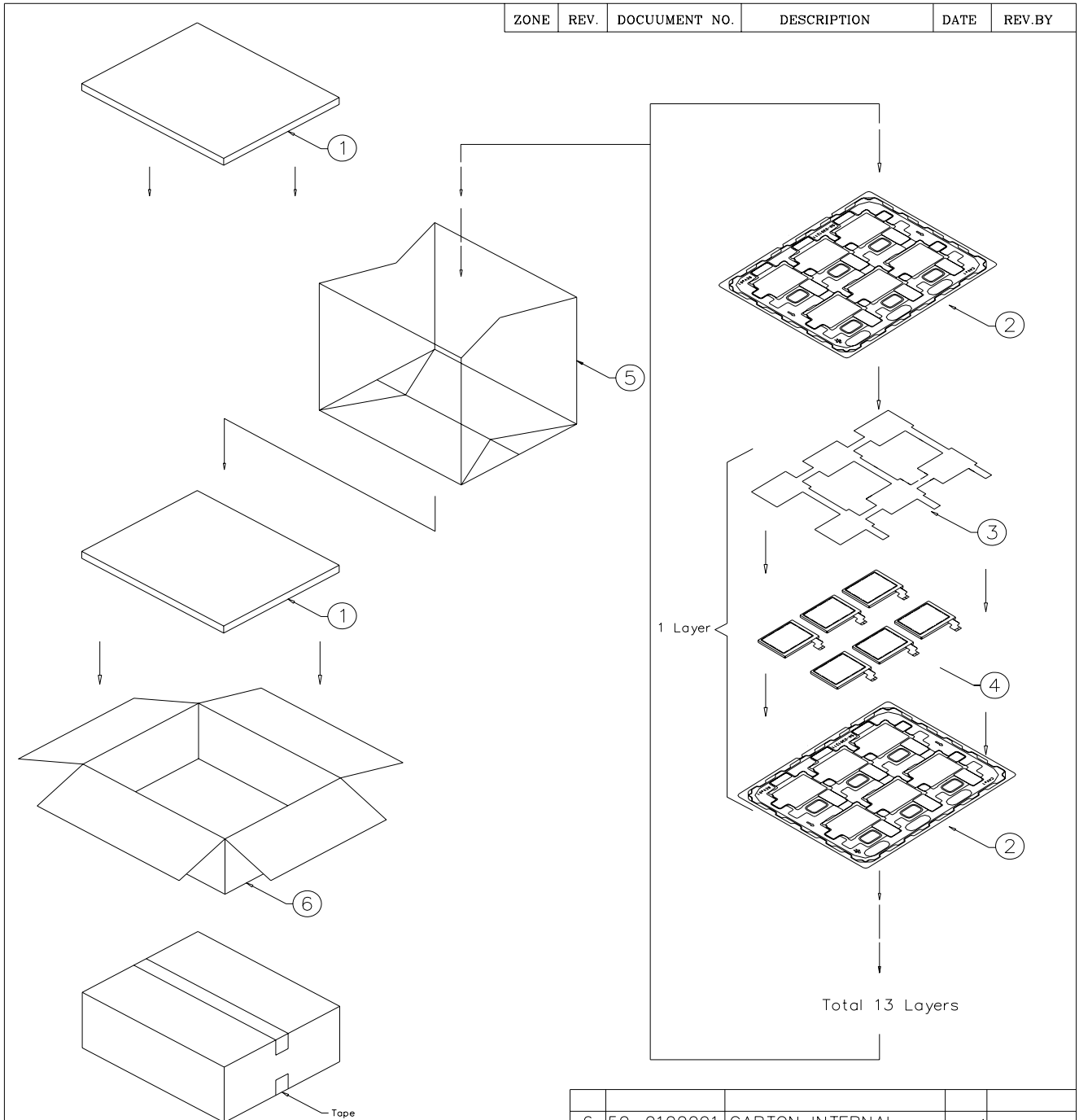

NOTE:

1. One layer include: 1 piece of cushion sheet, 6 pcs panel & 1 piece of tray.
2. Q'TY: 42 pcs panel/carton.
3. Dimension: 455*375*190mm
4. Weight: 5.3 KG

6	50-0100091	CARTON INTERNAL	1	
5	50-0500041	摺口袋450*380*700mm	1	抗靜電
4		PA040XS1	42	
3	50-0200061	EPE CUSHION SHEET	7	抗靜電
2	50-0301211	TRAY	8	抗靜電
1	50-0300491	EPE FOAM	2	
ITEM	PART NO.	DESCRIPTION	QTY	REMARK

MTL.SPEC.		UNSPECIFIED TOL'S		REMARK	
		ANGLE			
		ROUGHNESS			
APPROVE	Frank Shin	'05.09.08	SCALE	UNIT	SHEET
CHECK	Frank Shin	'05.09.08			1 OF 2
DESIGN	Patrick Lin	'05.09.08	MTL.NO.		DWG.NO.
					REV. 01
					A4 SIZE
元太科技股份有限公司 Prime View Internation Co.,ltd.					
DWG.TITLE PA040XS1 PACKING Dim					

ZONE	REV.	DOCUUMENT NO.	DESCRIPTION	DATE	REV.BY
------	------	---------------	-------------	------	--------

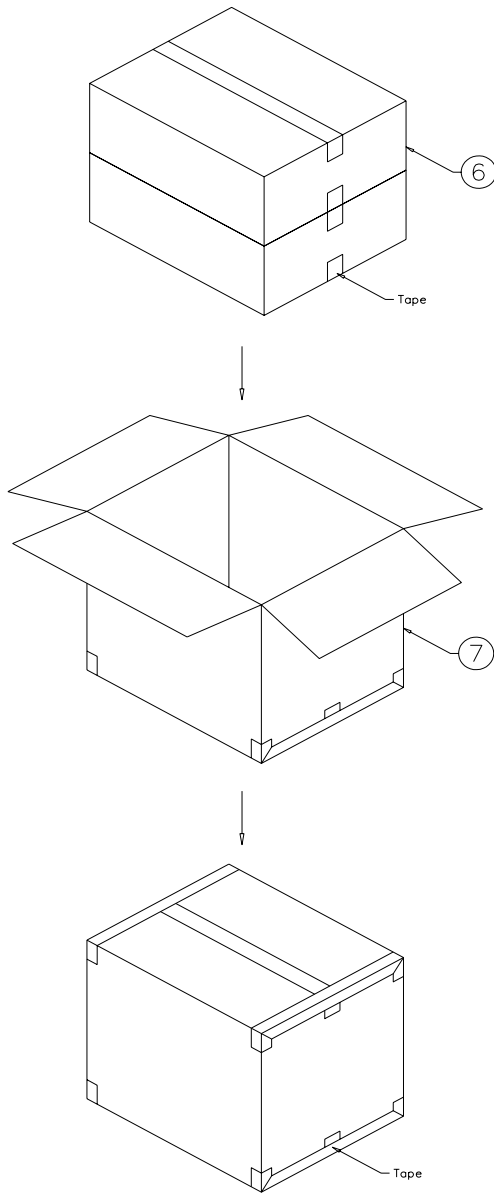
NOTE:

- Q'TY: 84 pcs panel/carton.
- Dimension: 480*396*405mm
- Weight: 11.5 KG

ITEM	PART NO.	DESCRIPTION	QTY	REMARK
7	50-0100101	CARTON EXTERNAL	1	

MTL.SPEC.		UNSPECIFIED TOL'S		REMARK		 元太科技股份有限公司 Prime View Internation Co.,ltd.	
		ANGLE					
		ROUGHNESS				DWG.TITLE	
APPROVE	Frank Shin	'05.09.08	SCALE	UNIT	SHEET	PA040XS1 PACKING Dim	
CHECK	Frank Shin	'05.09.08			2 OF 2		
DESIGN	Patrick Lin	'05.09.08	MTL.NO.			DWG.NO.	REV. 01
							A4 SIZE

