

Version : 1.0

TECHNICAL SPECIFICATION
MODEL NO : PD040QT2

The content of this information is subject to be changed without notice.
Please contact PVI or its agent for further information.

Customer's Confirmation

Customer _____

Date _____

By _____

PVI's Confirmation

Confirmed By Jimmy Chang

Prepared By 曾耀廷

Revision History

Rev.	Issued	Date	Revised	Contents
1.0		June, 4, 2008	New	

TECHNICAL SPECIFICATION CONTENTS

NO.	ITEM	PAGE
-	Cover	1
-	Revision History	2
-	Contents	3
1	Application	4
2	Features	4
3	Mechanical Specifications	4
4	Mechanical Drawing of TFT-LCD module	5
5	Input / Output Terminals	6
6	Pixel Arrangement	7
7	Absolute Maximum Ratings	7
8	Electrical Characteristics	8
9	Display Color and Gray Scale Reference	9
10	Interface Timing	10
11	Power On Sequence	13
12	Optical Characteristics	13
13	Handling Cautions	16
14	Reliability Test	17
15	Block Diagram	18
16	Packing	19

1. Application

This data sheet applies to a color TFT LCD module, PD040QT2. This module applies to OA product (must use Analog to Digital driving board), which requires high quality flat panel display. If you must use in severe reliability environment, please don't extend over PVI's reliability test conditions.

2. Features

- . Amorphous silicon TFT LCD panel with LED back-light unit
- . Pixel in stripe configuration
- . Slim and compact, designed for O/A application
- . TTL transmission interface

3. Mechanical Specifications

Parameter	Specifications	Unit
Screen Size	4 (diagonal)	inch
Display Format	320×(RGB)×240	dot
Active Area	81.12 (H)×60.84 (V)	mm
Pixel Pitch	0.2535(H)×0.2535 (V)	mm
Pixel Configuration	Stripe	
Display Colors	262,144	
Surface Treatment	Anti-Glare +EWV	
Back-light	8-LEDs	
Outline Dimension	93.00(W)×74.10 (H)×8.30 (D)(typ.)	mm
Weight	78±5	g
Display mode	Normally white	
Gray scale inversion direction	6 (ref to Note 12-1)	o'clock

4. Mechanical Drawing of TFT-LCD Module

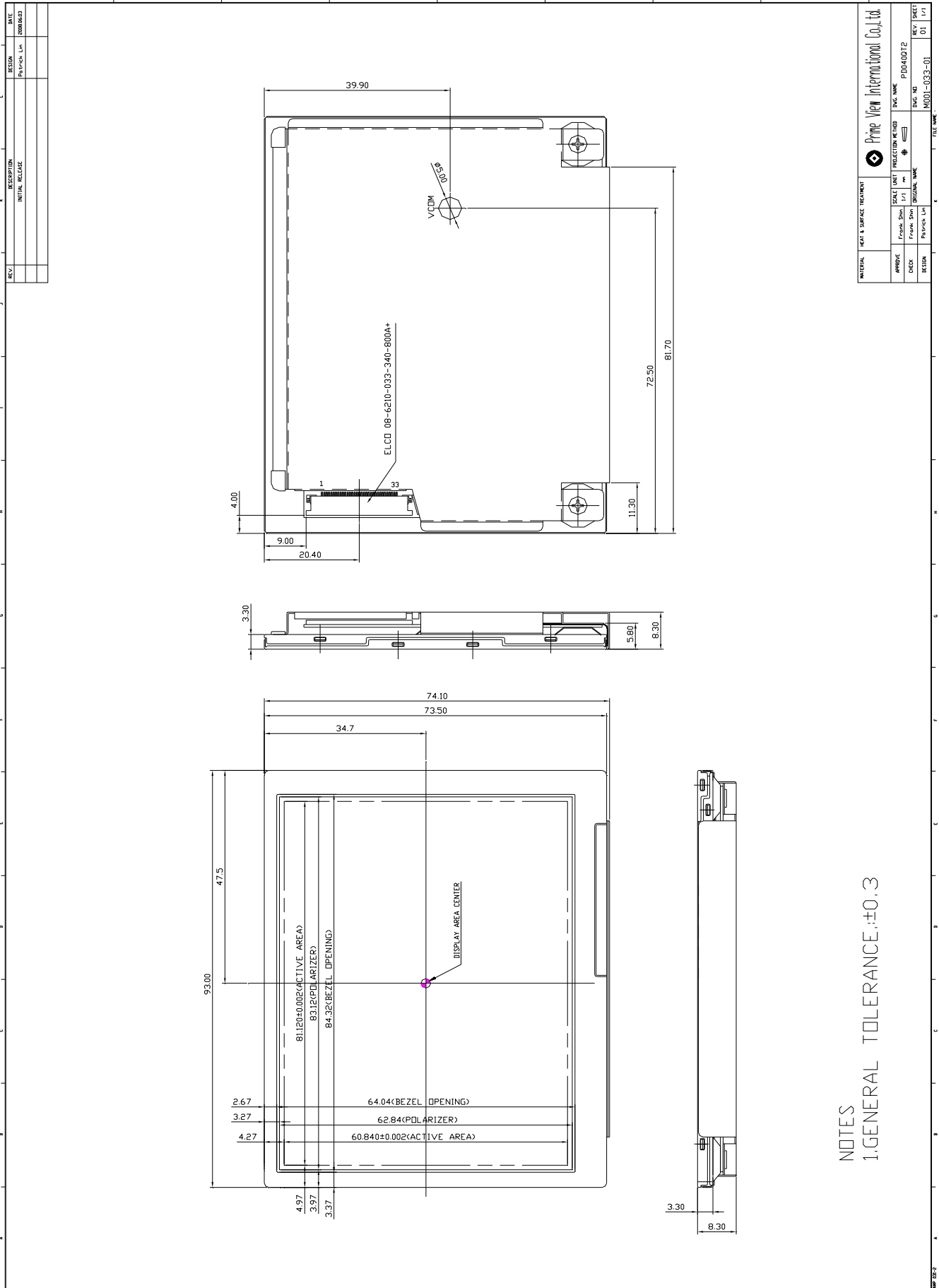

5. Input / Output Terminals
5-1) TFT-LCD Panel Driving

Connector type: ELCO 08-6210-033-340-800A+ , PIN No 33 pins, pitch=0.5mm

Pin No	Symbol	I/O	Description	Remark
1	GND	-	GND	
2	CK	I	Clock signal for sampling each data signal	
3	Hsync	I	Horizontal synchronous signal(negative)	
4	Vsync	I	Vertical synchronous signal(negative)	
5	GND	-	GND	
6	R0		RED data signal(LSB)	
7	R1	I	RED data signal	
8	R2	I	RED data signal	
9	R3	I	RED data signal	
10	R4	I	RED data signal	
11	R5	I	RED data signal(MSB)	
12	GND	-	GND	
13	G0	I	GREEN data signal(LSB)	
14	G1	I	GREEN data signal	
15	G2	I	GREEN data signal	
16	G3	I	GREEN data signal	
17	G4	I	GREEN data signal	
18	G5	I	GREEN data signal(MSB)	
19	GND	-	GND	
20	B0	I	Blue data signal(LSB)	
21	B1	I	Blue data signal	
22	B2	I	Blue data signal	
23	B3	I	Blue data signal	
24	B4	I	Blue data signal	
25	B5	I	Blue data signal(MSB)	
26	GND	-	GND	
27	DENB	I	Signal to settle the horizontal display position(positive)	Note5-1
28	V _{CC}	-	+3.3V power supply	
29	V _{CC}	-	+3.3V power supply	
30	R/L	I	Horizontal display mode select signal L : Normal ,H : Left /Right reverse mode	Note5-2
31	U/D	I	Vertical display mode select signal L : Normal ,H :Up/Down reverse mode	Note5-3
32	LED_A	I	LED Power (Anode)	
33	LED_C	I	LED Power (Cathode)	

Note5-1 : The horizontal display start timing is settled in accordance with rising of DENB signal.
In case ENAB is fixed "Low", the horizontal start timing is determined as described in 10-2. Don't keep DENB "High" during operation.

Note 5-2 , 5-3 : The definitions of U/D & R/L

U/D(PIN31)=Low R/L(PIN30)= Low

U/D(PIN31)=High R/L (PIN30)= High

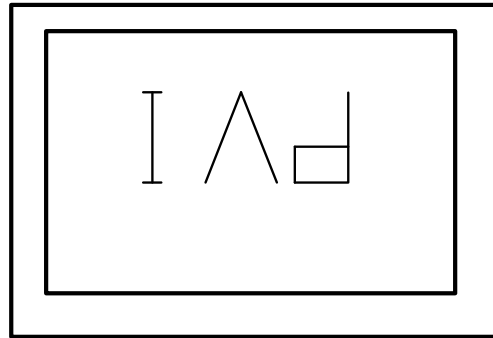
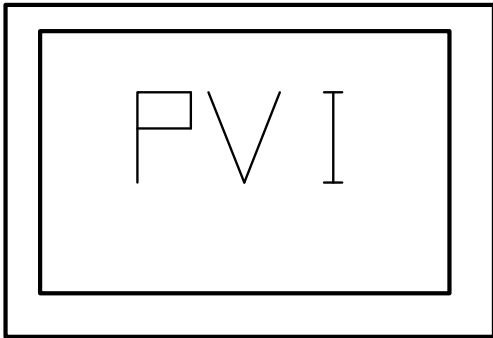

6. Pixel Arrangement

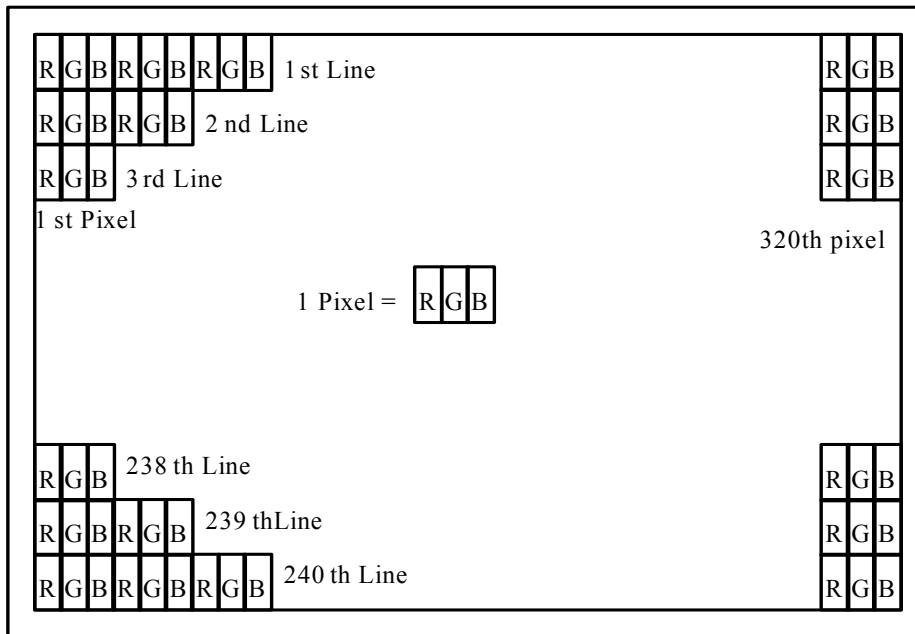

7. Absolute Maximum Ratings:

GND=0V, Ta=25°C

Parameters	Symbol	MIN	MAX.	Unit	Remark
Supply Voltage	V _{CC}	0	3.6	V	
Input Signals Voltage	V _{IN}	-0.3	4	V	

8. Electrical Characteristics

8-1) Recommended Operating Conditions:

GND=0V, Ta=25°C

Item	Symbol	Min.	Typ.	Max.	Unit	Remark
Supply Voltage	V _{CC}	3.0	3.3	3.6	V	
Current Dissipation	I _{CC}	-	50	-	mA	Note 8-1
Total power consumption	P _{CC}	150	165	180	mW	
Digital input voltage	High Level	V _{IH}	0.7V _{CC}	-	0.3V _{CC}	
	Low Level	V _{IL}	0	-	V _{CC}	
V _{com} Voltage	V _{com}	-	4	-	V	

Note 8-1 : To test the current dissipation of V_{CC}, using the “color bars” testing pattern shown as below.

1	2	3	4	5	6	7	8
---	---	---	---	---	---	---	---

1. White
2. Yellow
3. Cyan
4. Green
5. Magenta
6. Red
7. Blue
8. Black

I_{DD} current dissipation testing pattern

7-2) Recommended Driving Condition for Back Light

Ta=25°C

Parameter	Symbol	Min.	Typ.	Max.	Unit	Remark
Supply voltage of LED backlight	V _{LED}	-	-	(14)	V	Note 7-2
Supply current of LED backlight	I _{LED}	-	20	-	mA	Note 7-3
Backlight Power Consumption	P _{LED}	-	-	560	mW	Note 7-2、7-4

Note 7-2 : I_{LED}= 20mA, constant current

Note 7-3 : The LED driving condition is defined for each LED module. (4 LED Serial)

$$\text{Input current} = 20\text{mA} * 2 = 40\text{mA}$$

Note 7-4 : P_{LED} = V_{LED-1} * I_{LED-1} + V_{LED-2} * I_{LED-2}

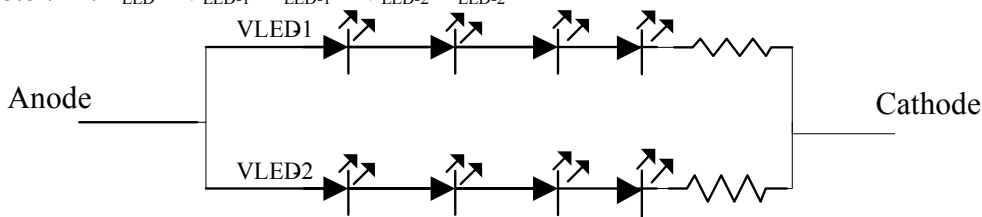

9. Display Color and Gray Scale Reference

Color		Input Color Data																	
		Red						Green						Blue					
		R5	R4	R3	R2	R1	R0	G5	G4	G3	G2	G1	G0	B5	B4	B3	B2	B1	B0
Basic Colors	Black	0	0	0	0	0	0	0	0	0	0	0	0	0	0	0	0	0	0
	Red (63)	1	1	1	1	1	1	0	0	0	0	0	0	0	0	0	0	0	0
	Green (63)	0	0	0	0	0	0	1	1	1	1	1	1	0	0	0	0	0	0
	Blue (63)	0	0	0	0	0	0	0	0	0	0	0	0	1	1	1	1	1	1
	Cyan	0	0	0	0	0	0	1	1	1	1	1	1	1	1	1	1	1	1
	Magenta	1	1	1	1	1	1	0	0	0	0	0	0	1	1	1	1	1	1
	Yellow	1	1	1	1	1	1	1	1	1	1	1	1	0	0	0	0	0	0
	White	1	1	1	1	1	1	1	1	1	1	1	1	1	1	1	1	1	1
Red	Red (00)	0	0	0	0	0	0	0	0	0	0	0	0	0	0	0	0	0	0
	Red (01)	0	0	0	0	0	1	0	0	0	0	0	0	0	0	0	0	0	0
	Red (02)	0	0	0	0	1	0	0	0	0	0	0	0	0	0	0	0	0	0
	Darker																		
	↓	↓	↓	↓	↓	↓	↓	↓	↓	↓	↓	↓	↓	↓	↓	↓	↓	↓	↓
	Brighter																		
	Red (61)	1	1	1	1	0	1	0	0	0	0	0	0	0	0	0	0	0	0
	Red (62)	1	1	1	1	1	0	0	0	0	0	0	0	0	0	0	0	0	0
	Red (63)	1	1	1	1	1	1	0	0	0	0	0	0	0	0	0	0	0	0
Green	Green (00)	0	0	0	0	0	0	0	0	0	0	0	0	0	0	0	0	0	0
	Green (01)	0	0	0	0	0	0	0	0	0	0	0	1	0	0	0	0	0	0
	Green (02)	0	0	0	0	0	0	0	0	0	0	1	0	0	0	0	0	0	0
	Darker																		
	↓	↓	↓	↓	↓	↓	↓	↓	↓	↓	↓	↓	↓	↓	↓	↓	↓	↓	↓
	Brighter																		
	Green (61)	0	0	0	0	0	0	1	1	1	1	0	1	0	0	0	0	0	0
	Green (62)	0	0	0	0	0	0	1	1	1	1	1	0	0	0	0	0	0	0
	Green (63)	0	0	0	0	0	0	1	1	1	1	1	1	0	0	0	0	0	0
Blue	Blue (00)	0	0	0	0	0	0	0	0	0	0	0	0	0	0	0	0	0	0
	Blue (01)	0	0	0	0	0	0	0	0	0	0	0	0	0	0	0	0	0	1
	Blue (02)	0	0	0	0	0	0	0	0	0	0	0	0	0	0	0	0	1	0
	Darker																		
	↓	↓	↓	↓	↓	↓	↓	↓	↓	↓	↓	↓	↓	↓	↓	↓	↓	↓	↓
	Brighter																		
	Blue (61)	0	0	0	0	0	0	0	0	0	0	0	0	1	1	1	1	0	1
	Blue (62)	0	0	0	0	0	0	0	0	0	0	0	0	1	1	1	1	1	0
	Blue (63)	0	0	0	0	0	0	0	0	0	0	0	0	1	1	1	1	1	1

10. Interface Timing
10-1) Timing Parameters

AC Electrical Characteristics ($V_{CC} = +3.3V, GND = 0V, T_a = 25^\circ C$)

		Symbol	Min.	Typ.	Max.	Unit
Power supply		VCC	3.0	3.3	3.6	V
CLK	Frequency	1/tc	-	6.3	7.0	MHz
		tc	-	50	-	ns
HSYNC	Period	Hp	-	63.6	-	us
			-	400	-	tc
	Display period	Hdp	-	320	-	tc
	Pulse width	Hpw	5	30	-	tc
	Back-porch	Hbp	-	38	-	tc
	Front-porch	Hfp	-	12	-	tc
	Hpw+Hbp			-	68	-
Hsync-CLK		Hhc	10	-	Tc-10	ns
VSYNC	Period	Vp	-	16.8	-	ms
			-	262	288	Hp
	Display period	Vdp	-	240	-	Hp
	Pulse width	Vpw	-	3	-	Hp
	Back-porch	Vbp	-	15	-	Hp
	Front-porch	Vfp	-	6	-	Hp
Vpw+Vbp			-	18	-	Hp
DENB	Horizontal scanning period	T1	-	400	-	tc
	Horizontal display period	T2	-	320	-	tc
	Vertical display period	T3	-	240	-	T1
	Frame cycling period	T4	-	262	288	T1
R,G,B	CLK-DATA	Dcd	10	-	-	ns
	DATA-CLK	Ddc	8	-	-	ns

10-2) Timing Diagram

a.1 Input signal range

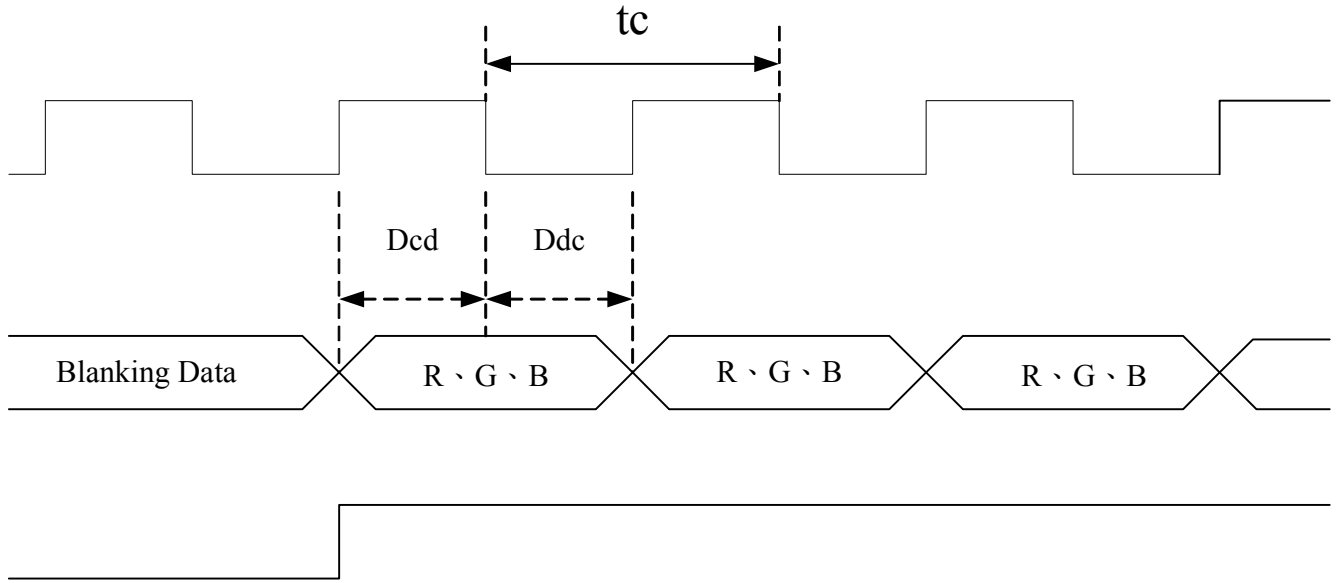

a.2 HSYNC timing

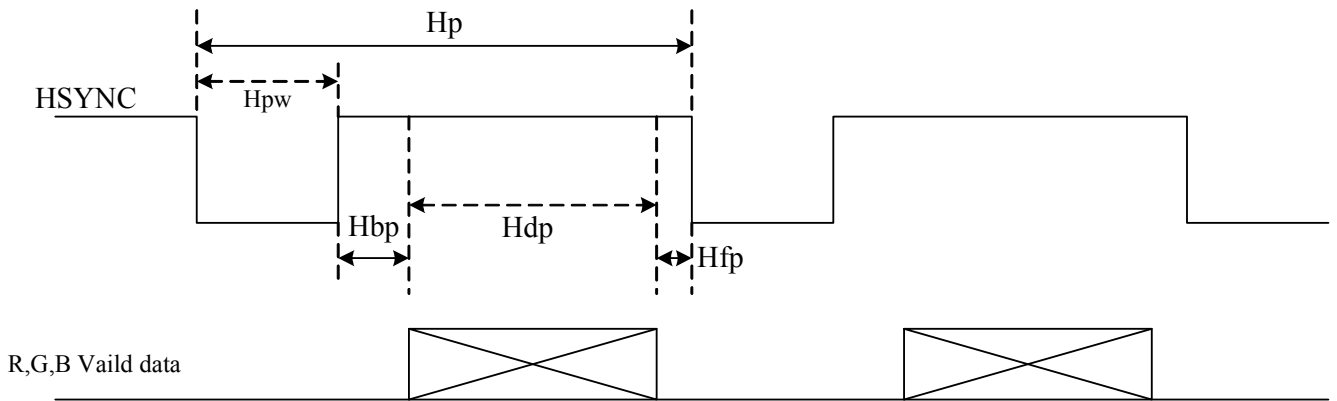

a.3 CLK, HSYNC relationship

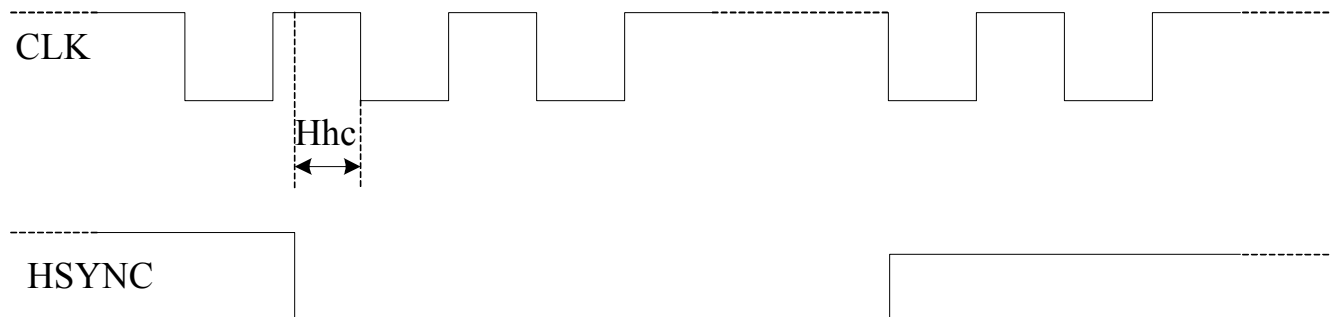

a.4 VSYNC timing

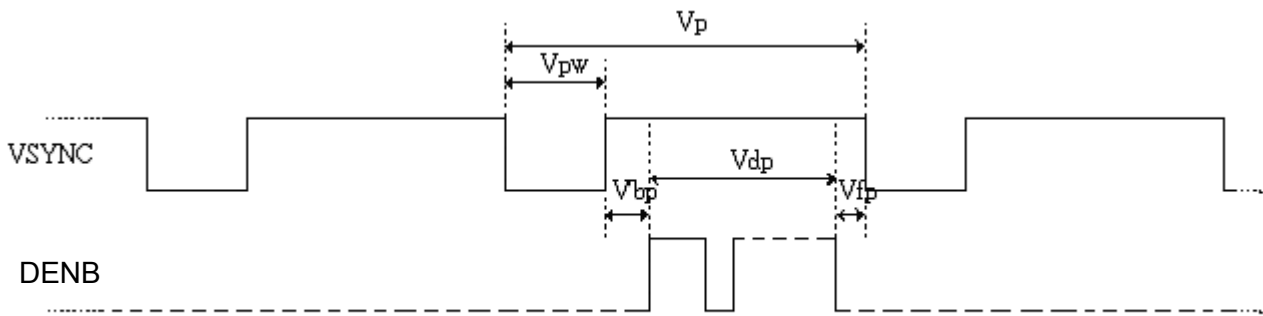

a.5 DENB timing

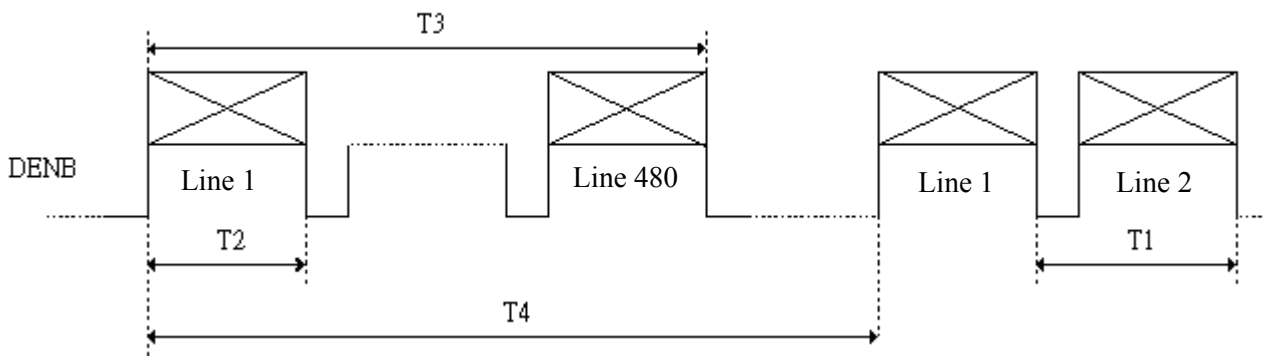

11. Power On Sequence

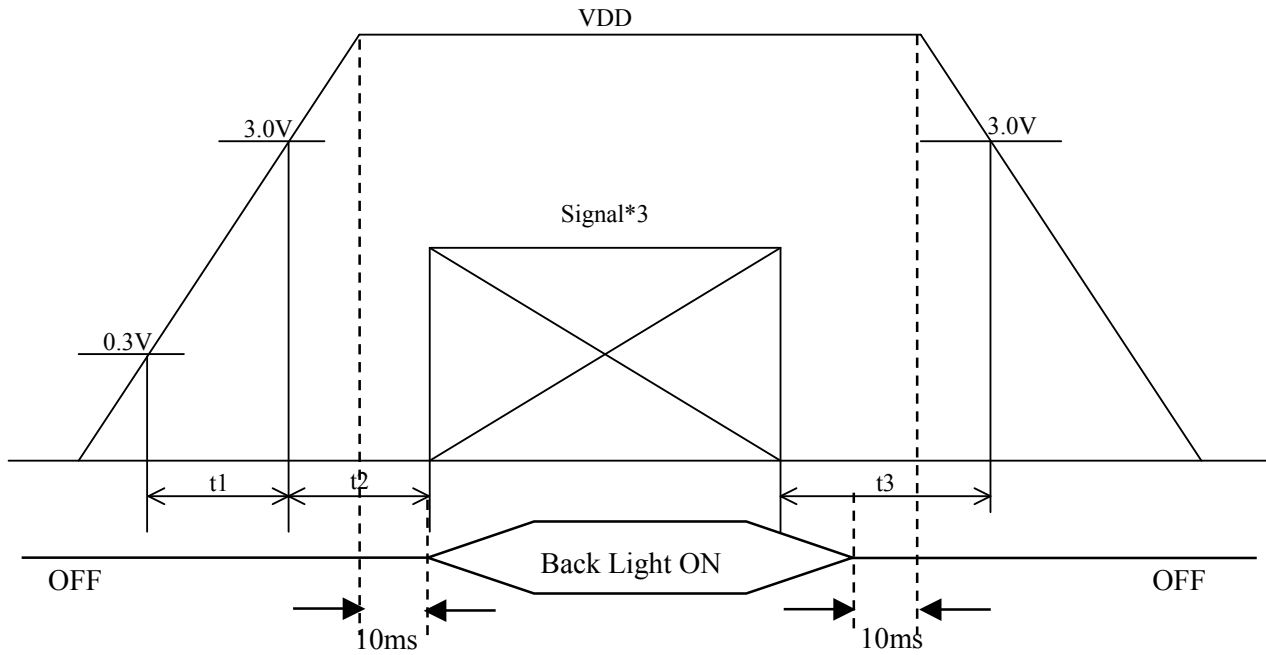

1. $0 < t1 \leq 20ms$
2. $0 < t2 \leq 50ms$
3. $0 < t3 \leq 1s$

12. Optical Characteristics

12-1) Specification:

Ta = 25°C

Parameter	Symbol	Condition	MIN.	TYP.	MAX.	Unit	Remarks
Viewing Angle	Horizontal	$\theta 21, \theta 22$	75	80	---	deg	Note 12-1
	Vertical	$\theta 12$	45	50	---	deg	
		$\theta 11$	55	60	---	deg	
Contrast Ratio	CR	At optimized Viewing angle	200	400	---		Note 12-2
Luminance	L	$\theta = 0^\circ$	300	350	---	cd/m ²	
White Chromaticity	x	$\theta = 0^\circ$	0.26	0.30	0.34		
	y	$\theta = 0^\circ$	0.29	0.33	0.37		
Response time	Rise	Tr	---	15	30	ms	Note 12-3
	Fall	Tf	---	25	50	ms	
Uniformity	U	-	75	80	---	%	Note 12-5
Cross Talk Ratio	CTK	-	---	---	3.5	%	Note 12-6
LED Life Time		+25°C	20000	30000	---	hrs	Note 12-4

Note 12-1 : The definitions of viewing angles

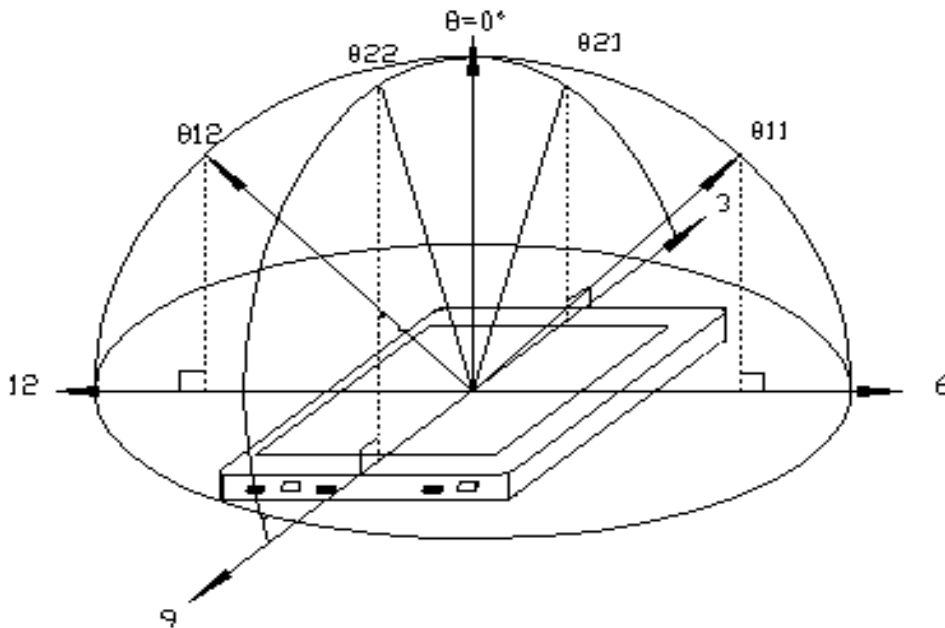

Note 12-2 : $CR = \frac{\text{Luminance when Testing point is White}}{\text{Luminance when Testing point is Black}}$

Contrast Ratio is measured in optimum common electrode voltage.

Note 12-3 : The definition of response time :

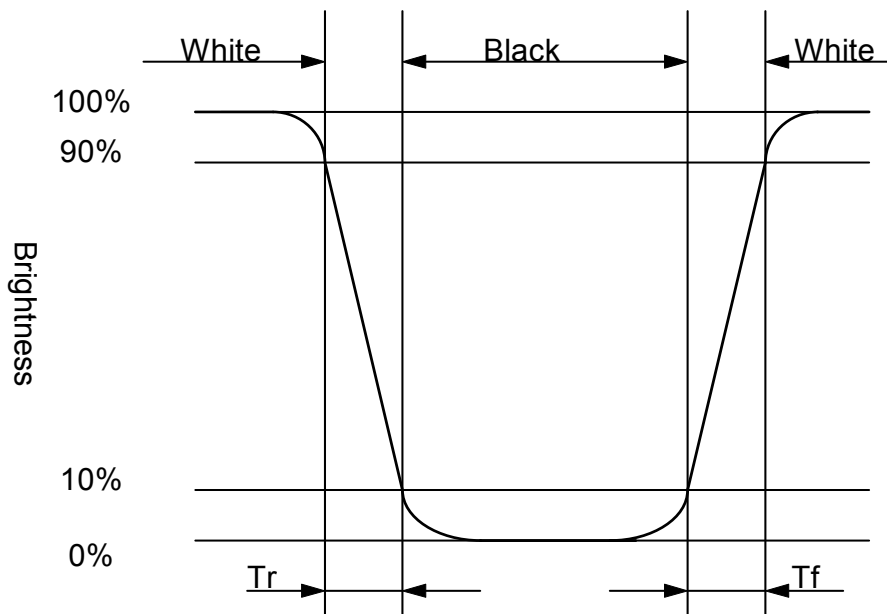

Note 12-4 : The "LED Life time " is defined as the module brightness decrease to 50% original Brightness that the ambient temperature is 25°C and $I_{LED} = 40mA$

Note 12-5: The uniformity of LCD is defined as

$$U = \frac{\text{The Minimum Brightness of the 9 testing Points}}{\text{The Maximum Brightness of the 9 testing Points}}$$

Luminance meter : BM-5A or BM-7 fast(TOPCON)
 Measurement distance : 500 mm +/- 50 mm
 Ambient illumination : < 1 Lux
 Measuring direction : Perpendicular to the surface of module
 The test pattern is white

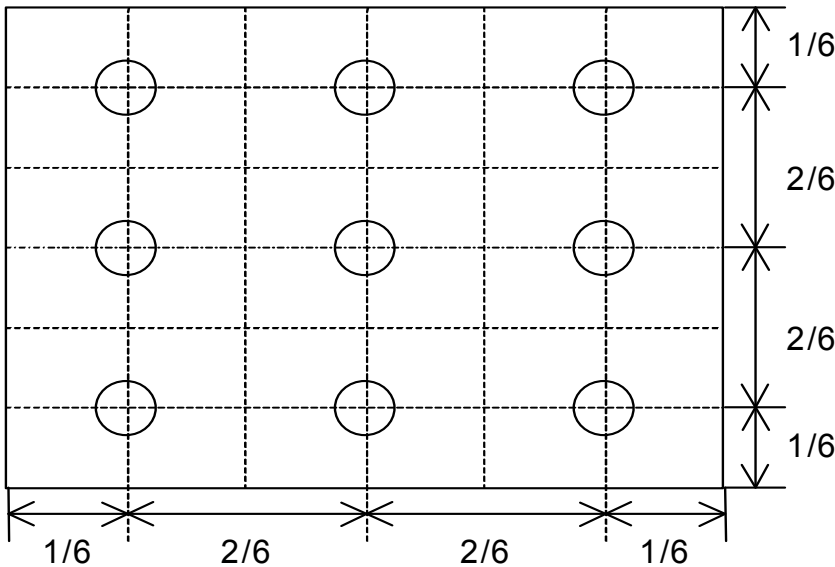

Note 12-6: Cross Talk (CTK) = $\frac{|YA-YB|}{YA} \times 100\%$

YA: Brightness of Pattern A
 YB: Brightness of Pattern B
 Luminance meter : BM 5A (TOPCON)
 Measurement distance : 500 mm +/- 50 mm
 Ambient illumination : < 1 Lux
 Measuring direction : Perpendicular to the surface of module

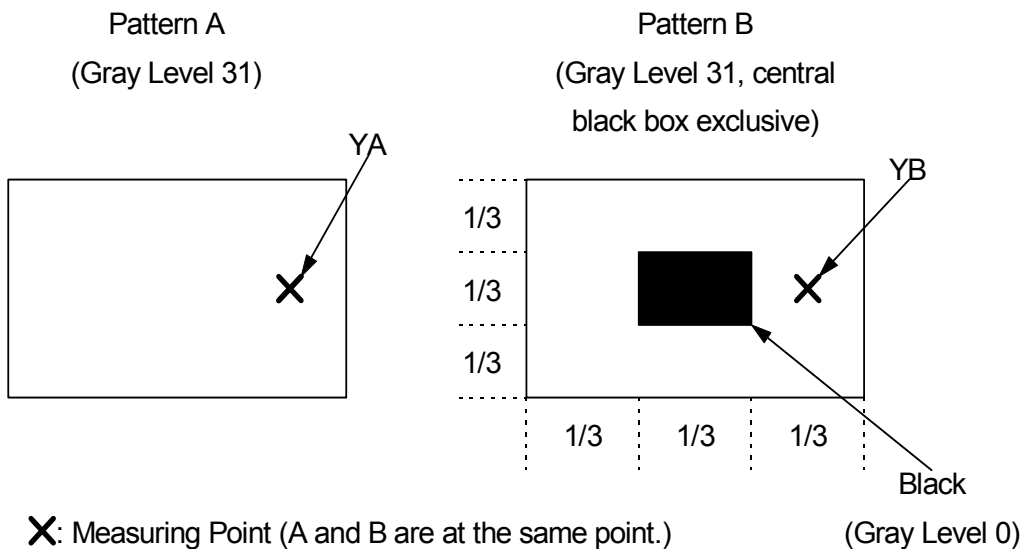

13. Handling Cautions

13-1) Mounting of module

- A) Please power off the module when you connect the input/output connector.
- B) Polarizer which is made of soft material and susceptible to flaw must be handled carefully.
- C) Protective film (Laminator) is applied on surface to protect it against scratches and dirt.
- D) Please following the tear off direction as figure13-1 to remove the protective film as slowly as possible, so that electrostatic charge can be minimized.

13-2) Precautions in mounting

- A) When metal part of the TFT-LCD module (shielding lid and rear case) is soiled, wipe it with soft dry cloth.
- B) Wipe off water drops or finger grease immediately. Long contact with water may cause discoloration or spots.
- C) TFT-LCD module uses glass which breaks or cracks easily if dropped or bumped on hard surface. Please handle with care.
- D) Since CMOS LSI is used in the module. So take care of static electricity and earth yourself when handling.

13-3) Adjusting module

- A) Adjusting volumes on the rear face of the module have been set optimally before shipment.
- B) Therefore, do not change any adjusted values. If adjusted values are changed, the specifications described may not be satisfied.

13-4) Others

- A) Do not expose the module to direct sunlight or intensive ultraviolet rays for many hours.
- B) Store the module at a room temperature place.
- C) The voltage of beginning electric discharge may over the normal voltage because of leakage current from approach conductor by to draw lump read lead line around.
- D) If LCD panel breaks, it is possibly that the liquid crystal escapes from the panel. Avoid putting it into eyes or mouth. When liquid crystal sticks on hands, clothes or feet. Wash it out immediately with soap.
- E) Observe all other precautionary requirements in handling general electronic components.
- F) Please adjust the voltage of common electrode as material of attachment by 1 module.

13-5) Polarizer mark

The polarizer mark is to describe the direction of view angle film how to mach up with the rubbing direction.

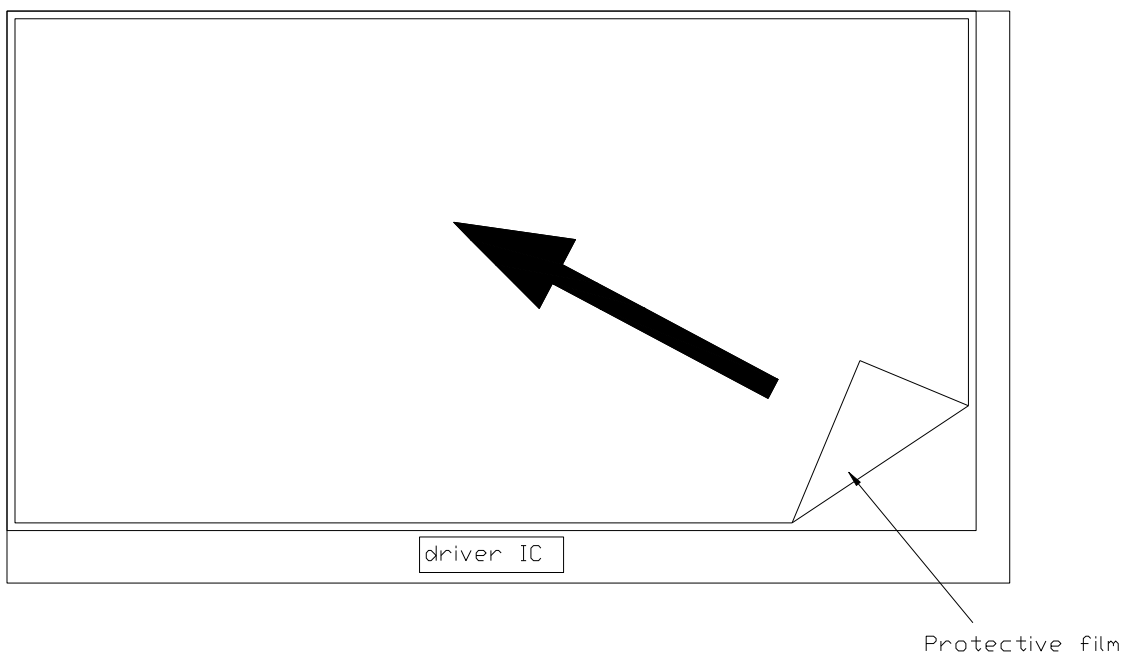

Figure 13-1 the way to peel off protective film

14. Reliability Test

No	Test Item	Test Condition
1	High Temperature Storage Test	Ta = +85°C, 240 hrs
2	Low Temperature Storage Test	Ta = -40°C, 240 hrs
3	High Temperature Operation Test	Ta = +85°C, 240 hrs
4	Low Temperature Operation Test	Ta = -30°C, 240 hrs
5	High Temperature & High Humidity Operation Test	Ta = +60°C, 90%RH, 240 hrs
6	Thermal Cycling Test (non-operating)	-30°C→+80°C, 200 Cycles, 30 min 30 min
7	Vibration Test (non-operating)	Frequency:10~55Hz Amplitude: 1.5mm Sweep time:11 mins Test Period:6 Cycles for each direction of X,Y,Z
8	Shock Test (non-operating)	100G, 6ms Direction : ±X, ±Y, ±Z Cycle : 3 times
9	Electrostatic Discharge Test (non-operating)	150pF, 330Ω Air : ±15KV ; Contact : ±8KV 10 times/point, 5 points/panel face

Ta: ambient temperature

Note : The protective film must be removed before temperature test.

[Criteria]

In the standard conditions, there is not display function NG issue occurred. (including : line defect ,no image).All the cosmetic specification is judged before the reliability stress.

15. Block Diagram

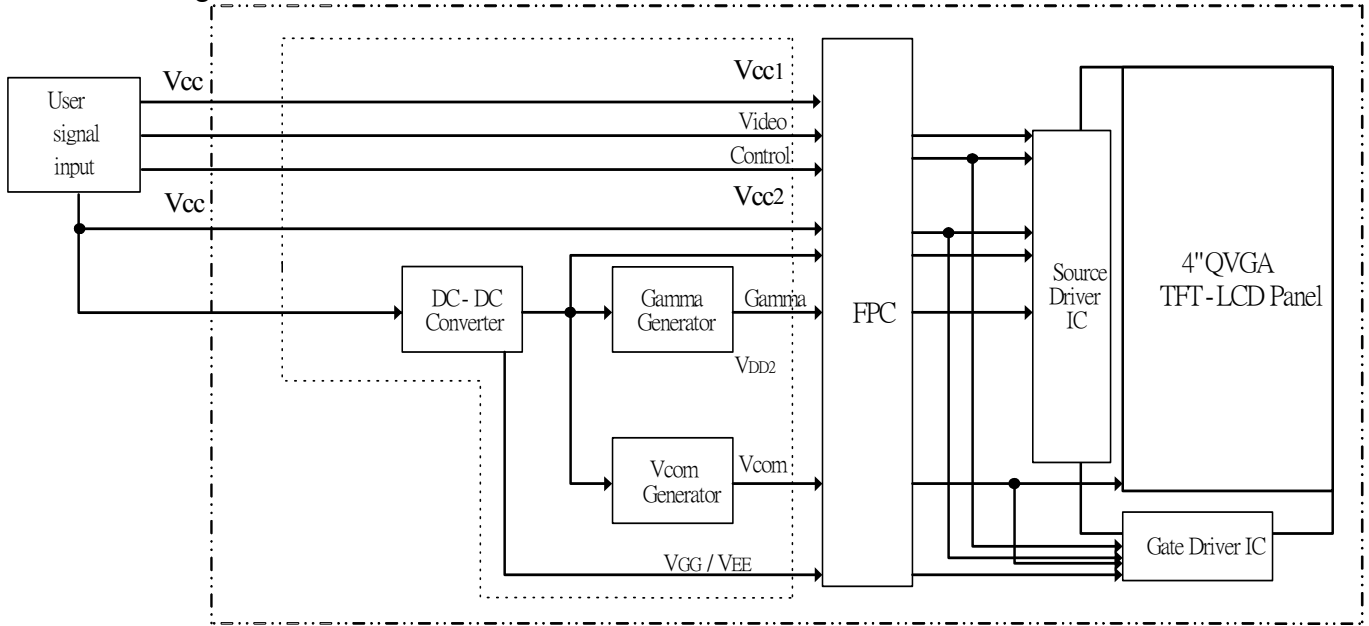

16. Packing

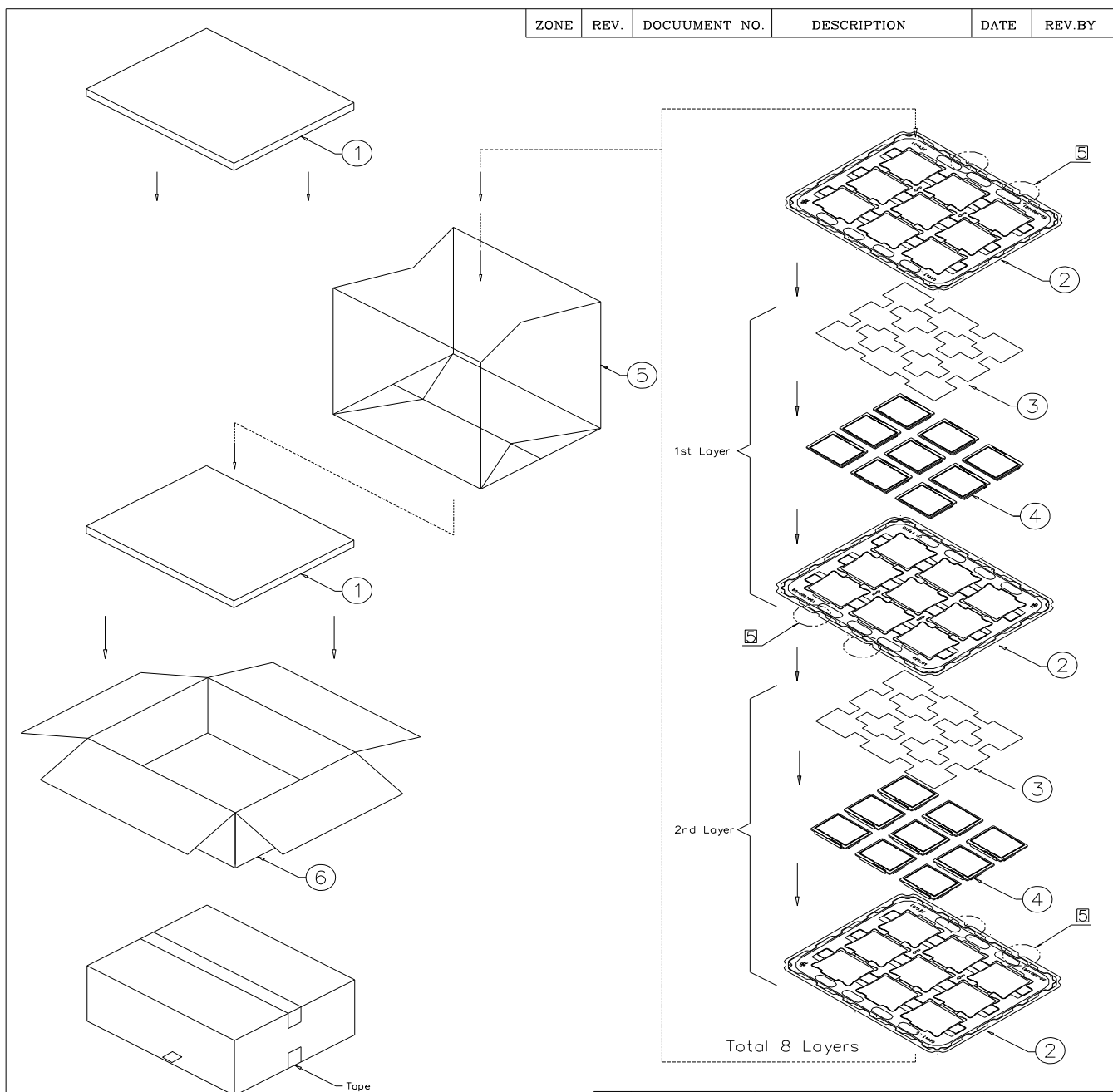

NOTE:

1. One layer include: 1 piece of cushion sheet, 9 pcs module & 1 piece of tray.
2. Q'TY: 72 pcs module/carton.
3. Dimension: 455*375*190mm
4. Weight: 8 KG
5. Tray 需180°交叉堆疊, 堆疊後可從側邊檢視圓弧防呆方向是否正確

ITEM	PART NO.	DESCRIPTION	QTY	REMARK
6	50-0100091	CARTON INTERNAL	1	
5	50-0500041	摺口袋450*380*700mm	1	抗靜電
4		PD040QT2	72	
3	50-0200106	EPE CUSHION SHEET	8	抗靜電
2	50-0301861	TRAY	9	抗靜電
1	50-0300491	EPE FOAM	2	

MTL.SPEC.		UNSPECIFIED TOL'S		REMARK	
		ANGLE			
		ROUGHNESS			
APPROVE	Frank Shin	'08.08.06	SCALE	UNIT	SHEET
CHECK	Frank Shin	'08.08.06			1 OF 1
DESIGN	Patrick Lin	'08.08.06	MTL.NO.		DWG.NO.
元太科技股份有限公司 Prime View International Co.,ltd.					
DWG.TITLE PD040QT2 PACKING					
					REV. 02
					A4 SIZE