

Version : 0.2

TECHNICAL SPECIFICATION

MODEL NO. : PD057VT2

The content of this information is subject to be changed without notice.
Please contact PVI or its agent for further information.

Customer's Confirmation

Customer _____

Date _____

By _____

PVI's Confirmation

Dep	FAE	Panel Design	Electronic Design	Mechanical Design	Product Verification	Prepared by
Sign	劉豐發	周珮如	金聖坤	楊秉勳	申峰	鄭文志
		周珮如				張文志
						吳昌霖

Revision History

Rev.	Issued Date	Eng.	Revised	Contents
0.1	May.23, 2007	吳昌霖		Preliminary
0.2	Jul. 10, 2007	吳昌霖		Add Page4 mechanical drawing

TECHNICAL SPECIFICATION

CONTENTS

NO.	ITEM	PAGE
-	Cover	1
-	Revision History	2
-	Contents	3
1	Application	4
2	Features	4
3	Mechanical Specifications	4
4	Mechanical Drawing of TFT-LCD module	5
5	Input / Output Terminals	6
6	Absolute Maximum Ratings	7
7	Electrical Characteristics	7
8	Pixel Arrangement	8
9	Display Color and Gray Scale Reference	9
10	Interface Timing	10
11	Power On Sequence	12
12	Optical Characteristics	12
13	Handling Cautions	16
14	Reliability Test	17
15	Packing Diagram	18

1. Application

This data sheet applies to a color TFT LCD module, PD057VT2.

PD057VT2 module applies to OA product, car TV (must use Analog to Digital driving board), which requires high quality flat panel display. If you must use in severe reliability environment, please don't extend over PVI's reliability test conditions.

2. Features

- . VGA (640*480 pixels) resolution
- . Amorphous silicon TFT LCD panel with back-light unit
- . Pixel in stripe configuration
- . Thin and light weight
- . Display Colors : 262,144 colors
- . TTL interface

3. Mechanical Specifications

Parameter	Specifications	Unit
Screen Size	5.7 (diagonal)	inch
Display Format	640×(R,G,B)×480	dot
Display Colors	262,144	
Active Area	115.20 (H)×86.4 (V)	mm
Pixel Pitch	0.18(H)×0.18(V)	mm
Pixel Configuration	Stripe	
Outline Dimension	144.0 (W)×104.6(H)×13.0 (D) (typ.)	mm
Weight	210±10	g
Back-light	CCFL , 1 tube	
Surface treatment	Anti-glare + EWV film	
Display mode	Normally white	
Gray scale inversion direction	6 o`clock	

4. Mechanical Drawing of TFT-LCD Module

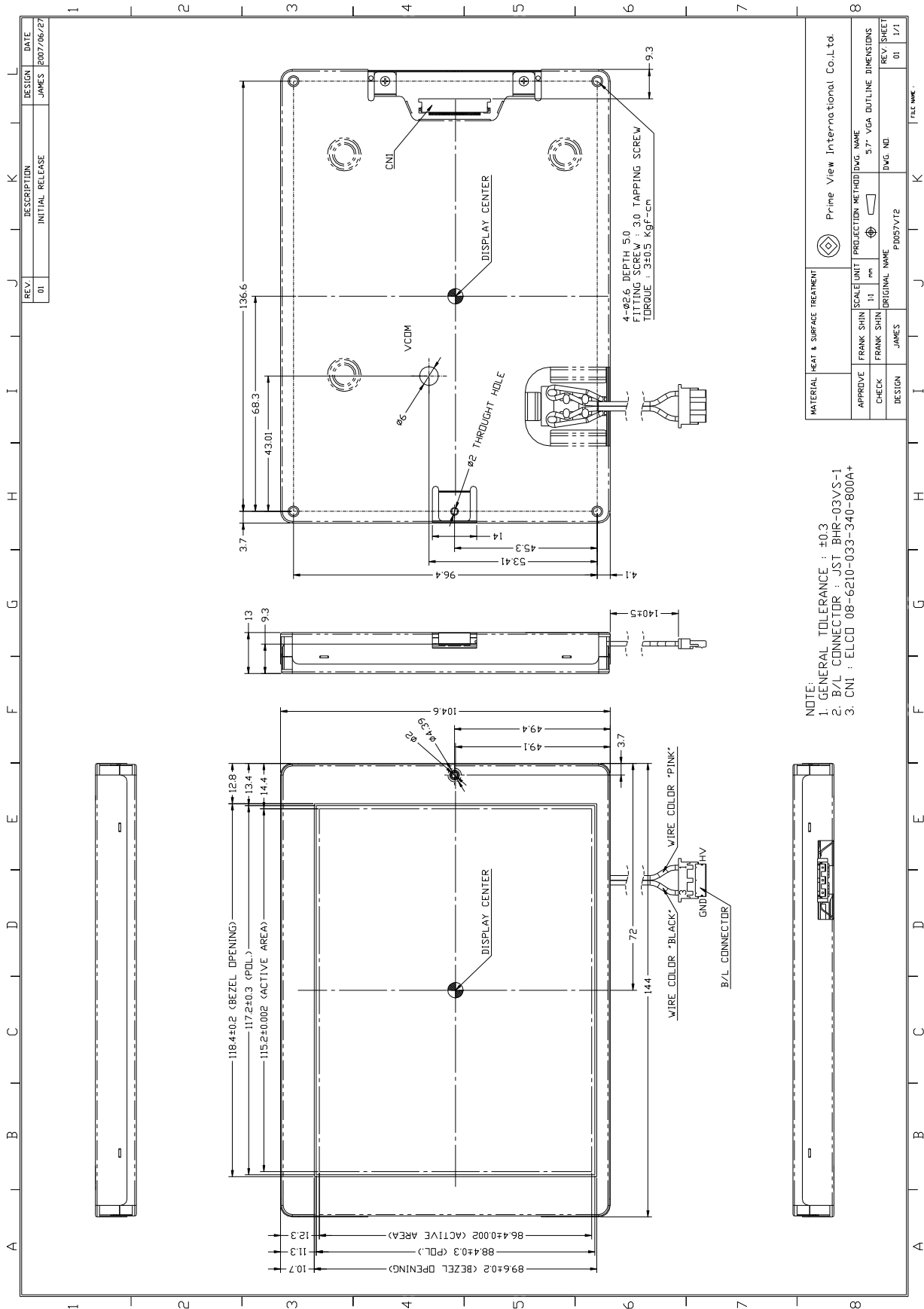

NOTE:
 1. GENERAL TOLERANCE : ±0.3
 2. B/L CONNECTOR : JST BHR-03VS-1
 3. CNI : ELCD 08-6210-033-340-800A+

MATERIAL HEAT & SURFACE TREATMENT		Prime View International Co., Ltd.	
APPROVE	FRANK SHIN	SCALE	UNIT
CHECK	FRANK SHIN	PROJECTION METHOD	DWG. NAME
DESIGN	JAMES	FILE NO.	5.7" VGA OUTLINE DIMENSIONS
DESIGNER		ORIGINAL NAME	REV. / SHEET
DESIGN		PD057VT2	01 / 1/1

5. Input / Output Terminals

5-1) TFT-LCD Panel Driving

Connector type: ELCO 08-6210-033-340-800A+ , PIN No 33 pins, pitch=0.5mm

Pin No	Symbol	I/O	Description	Remark
1	GND	-	GND	
2	CK	I	Clock signal for sampling each data signal	
3	Hsync	I	Horizontal synchronous signal (negative)	
4	Vsync	I	Vertical synchronous signal (negative)	
5	GND	-	GND	
6	R0		RED data signal (LSB)	
7	R1	I	RED data signal	
8	R2	I	RED data signal	
9	R3	I	RED data signal	
10	R4	I	RED data signal	
11	R5	I	RED data signal (MSB)	
12	GND	-	GND	
13	G0	I	GREEN data signal (LSB)	
14	G1	I	GREEN data signal	
15	G2	I	GREEN data signal	
16	G3	I	GREEN data signal	
17	G4	I	GREEN data signal	
18	G5	I	GREEN data signal (MSB)	
19	GND	-	GND	
20	B0	I	Blue data signal (LSB)	
21	B1	I	Blue data signal	
22	B2	I	Blue data signal	
23	B3	I	Blue data signal	
24	B4	I	Blue data signal	
25	B5	I	Blue data signal (MSB)	
26	GND	-	GND	
27	ENAB	I	Signal to settle the horizontal display position(positive)	Note5-1
28	V _{CC}	-	+3.3V power supply	
29	V _{CC}	-	+3.3V power supply	
30	R/L	I	Horizontal display mode select signal L : Normal , H : Left /Right reverse mode	Note5-2
31	U/D	I	Vertical display mode select signal H : Normal , L : Up/Down reverse mode	
32	V/Q	I	H : Normal	
33	GND	-	GND	

Note5-1 : The horizontal display start timing is settled in accordance with rising of ENAB signal.
In case ENAB is fixed "Low", the horizontal start timing is determined as described in 10-2. Don't keep ENAB "High" during operation.

Note 5-2 : The definitions of U/D & R/L

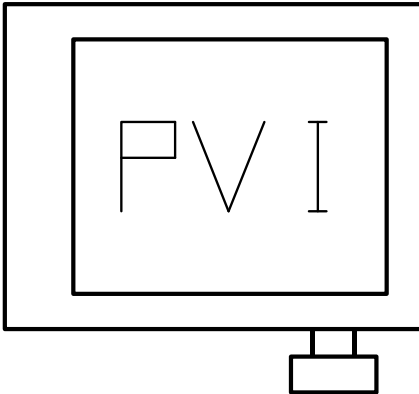

R/L(PIN 30)= Low, U/D(PIN 31)= High

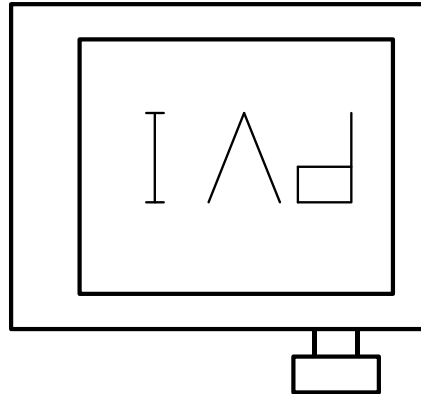

R/L(PIN 30)= High , U/D(PIN 31)= Low

5-2) Backlight driving

Connector type: JST BHR-03VS-1, PIN No 2 pins, pitch=3.5mm

Pin No	Symbol	Description	Remark
1	V _{High}	Power supply for lamp (High voltage side)	Red
-	NC	This is electrically opened	-
3	V _{Low}	Power supply for lamp (Low voltage side)	White

Note 5-3 : Low voltage side of backlight inverter connects with ground of inverter circuits.

6.Absolute Maximum Ratings:

GND=0V, Ta=25°C

Parameters	Symbol	Condition	MAX.	Unit	Remark
Input Voltage	V _I	Ta=25°C	-0.3~+4	V	Note6-1
+3.3V supply voltage	V _{CC}	Ta=25°C	0~+3.6	V	

Note6-1:CK,R0~R5,G0~G5,B0~B5,Hsync,Vsync,ENAB,R/L,U/D,V/Q

7.Electrical Characteristics

7-1) Recommended Operating Conditions:

GND=0V, Ta=25°C

Item	Symbol	Min.	Typ.	Max.	Unit	Remark
+3.3V Supply Voltage	V _{CC}	+3.0	+3.3	+3.6	V	
Permissive input ripple voltage	V _{RF}	-	-	100	mVp-p	V _{CC} =3.3V
Input voltage(Low)	V _{IL}	0	-	0.3 V _{CC}	V	
Input voltage(High)	V _{IH}	0.7 V _{CC}	-	V _{CC}	V	

7-2) Recommended Driving Condition for Back Light

Ta=25°C

Parameter	Symbol	Min.	Typ.	Max.	Unit	Remark
Lamp Voltage	V _L	639	710	781	V	I _L =5mA
Lamp Current	I _L	4	5	8	mA	Note 7-1
Lamp Frequency	P _L	-	35	-	KHz	Note 7-2
Starting Voltage (25°C) (Reference Value)	Vs	-	-	1240	Vrms	Note 7-3
Starting Voltage (0°C) (Reference Value)	Vs	-	-	1380	Vrms	Note 7-3

Note 7-1 : In order to have proper operation of the B/L, no matter what kind of inverters, the output lamp current must be between Min. and Max. values to avoid the abnormal display image caused by B/L.

Note 7-2 : The driving frequency of the lamp may interfere with the horizontal synch signal, leaving interference stripes on the display. So please evaluate LCD panels beforehand.

To avoid interference stripes, we recommend to separate as far as possible the lamp frequency from the horizontal synchronous signal and its high harmonic frequency.

The inverter which PVI uses is TAD347-1.

Note 7-3 : The “Starting Voltage” means the minimum voltage of inverter to turn on the lamp. And it should be applied to the lamp for more than 1 second to start up. Otherwise the lamp may not be turned on.

7-3) Power Consumption

Parameters	Symbol	Typ.	Max.	Unit	Remark
+3.3V Current Dissipation	I _{CC}	67	100	mA	
LCD Panel Power Consumption	-	0.22	0.33	W	Note 7-4
Backlight Power Consumption	-	3.55	3.91	W	Note 7-5

Note 7-4: The power consumption for back light is not included.

Note 7-5: Back light lamp power consumption is calculated by I_L×V_L.

8. Pixel Arrangement

The LCD module pixel arrangement is stripe configuration.

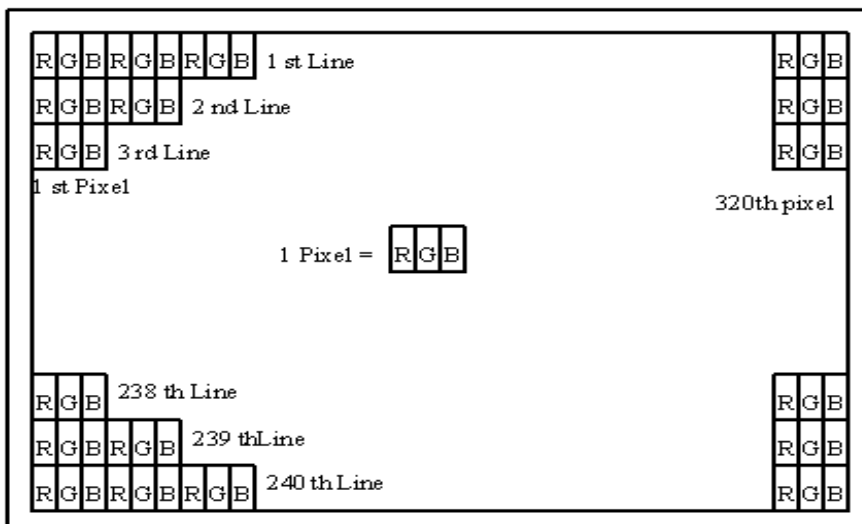

9. Display Color and Gray Scale Reference

Color		Input Color Data																	
		Red						Green						Blue					
		R5	R4	R3	R2	R1	R0	G5	G4	G3	G2	G1	G0	B5	B4	B3	B2	B1	B0
Basic Colors	Black	0	0	0	0	0	0	0	0	0	0	0	0	0	0	0	0	0	0
	Red (63)	1	1	1	1	1	1	0	0	0	0	0	0	0	0	0	0	0	0
	Green (63)	0	0	0	0	0	0	1	1	1	1	1	1	0	0	0	0	0	0
	Blue (63)	0	0	0	0	0	0	0	0	0	0	0	0	1	1	1	1	1	1
	Cyan	0	0	0	0	0	0	1	1	1	1	1	1	1	1	1	1	1	1
	Magenta	1	1	1	1	1	1	0	0	0	0	0	0	1	1	1	1	1	1
	Yellow	1	1	1	1	1	1	1	1	1	1	1	1	0	0	0	0	0	0
	White	1	1	1	1	1	1	1	1	1	1	1	1	1	1	1	1	1	1
Red	Red (00)	0	0	0	0	0	0	0	0	0	0	0	0	0	0	0	0	0	0
	Red (01)	0	0	0	0	0	1	0	0	0	0	0	0	0	0	0	0	0	0
	Red (02)	0	0	0	0	1	0	0	0	0	0	0	0	0	0	0	0	0	0
	Darker																		
	↓	↓	↓	↓	↓	↓	↓	↓	↓	↓	↓	↓	↓	↓	↓	↓	↓	↓	↓
	Brighter																		
	Red (61)	1	1	1	1	0	1	0	0	0	0	0	0	0	0	0	0	0	0
	Red (62)	1	1	1	1	1	0	0	0	0	0	0	0	0	0	0	0	0	0
	Red (63)	1	1	1	1	1	1	0	0	0	0	0	0	0	0	0	0	0	0
Green	Green (00)	0	0	0	0	0	0	0	0	0	0	0	0	0	0	0	0	0	0
	Green (01)	0	0	0	0	0	0	0	0	0	0	0	1	0	0	0	0	0	0
	Green (02)	0	0	0	0	0	0	0	0	0	0	1	0	0	0	0	0	0	0
	Darker																		
	↓	↓	↓	↓	↓	↓	↓	↓	↓	↓	↓	↓	↓	↓	↓	↓	↓	↓	↓
	Brighter																		
	Green (61)	0	0	0	0	0	0	1	1	1	1	0	1	0	0	0	0	0	0
	Green (62)	0	0	0	0	0	0	1	1	1	1	1	0	0	0	0	0	0	0
	Green (63)	0	0	0	0	0	0	1	1	1	1	1	1	0	0	0	0	0	0
Blue	Blue (00)	0	0	0	0	0	0	0	0	0	0	0	0	0	0	0	0	0	0
	Blue (01)	0	0	0	0	0	0	0	0	0	0	0	0	0	0	0	0	0	1
	Blue (02)	0	0	0	0	0	0	0	0	0	0	0	0	0	0	0	0	1	0
	Darker																		
	↓	↓	↓	↓	↓	↓	↓	↓	↓	↓	↓	↓	↓	↓	↓	↓	↓	↓	↓
	Brighter																		
	Blue (61)	0	0	0	0	0	0	0	0	0	0	0	0	1	1	1	1	0	1
	Blue (62)	0	0	0	0	0	0	0	0	0	0	0	0	1	1	1	1	1	0
	Blue (63)	0	0	0	0	0	0	0	0	0	0	0	0	1	1	1	1	1	1

10. Interface Timing

10-1) Timing Parameters

	Parameter	Symbol	Min.	Typ.	Max.	Unit
Clock	Frequency	1/Tcph	---	25.2	27.8	MHz
	"High" time	Tcwh	18	---	---	ns
	"Low" time	Tcwl	18	---	---	ns
Data	Setup time	Tdsu	10	---	---	ns
	Hold time	Tdhd	10	---	---	ns
Hsync	Period	TH	30.00	31.78	---	us
			770	800	900	clock
	Pulse width	TH _{WH}	5	30	---	clock
Vsync	Period	TV	515	525	560	line
	Pulse width	T _{WV}	1	3	5	line
Horizontal display period		THd	640	640	640	clock
Vertical display period		TVd	480	480	480	line

Note 10-1 : In case of low-frequency, the deterioration of display quality, flicker etc., may occur.

10-2) Display Position in horizontal direction

Display position in horizontal direction is designated by rising timing of ENAB signal.

	Parameter	Symbol	Min.	Typ.	Max.	Unit	Note
ENAB signal	Setup time	Tesu	10	---	---	ns	
	Pulse width	Tep	2	640	640	clock	
Phase difference between Hsync and ENAB signal		THs	112	144	175	clock	

When ENAB is fixed to "Low", the horizontal display will start from 144th clock after HS falling.

10-3) Display Position in vertical direction

Display start position in vertical direction is fixed to the 35th line.

The ENAB signal does not relate to Vertical display position.

10-4) Timing Diagram

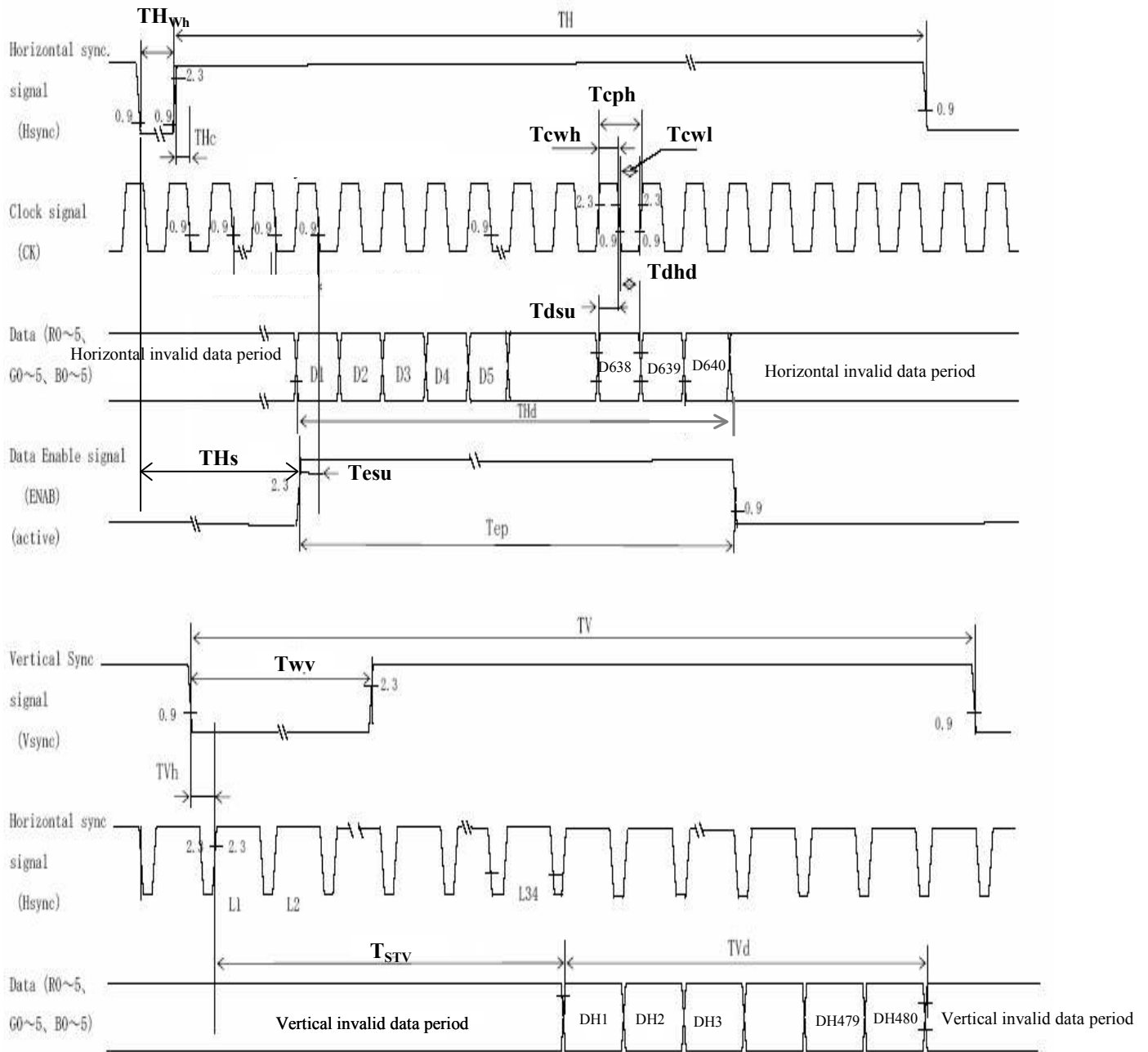

11. Power On Sequence

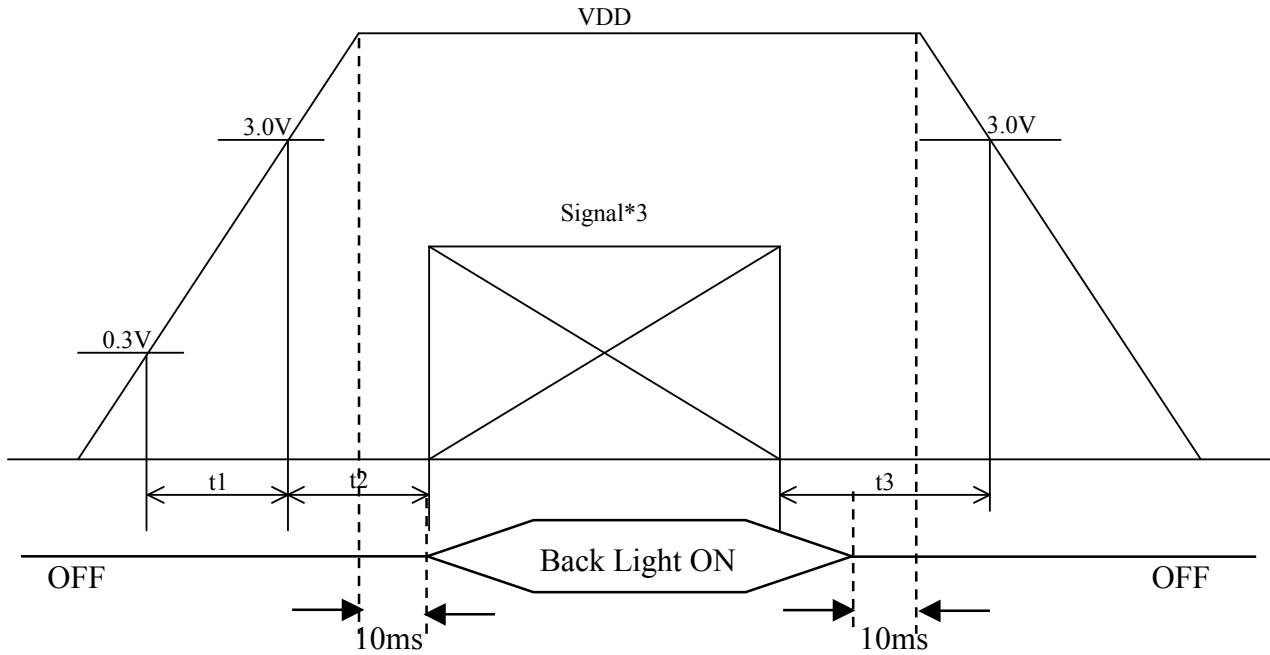

1. $0 < t_1 \leq 20\text{ms}$
2. $0 < t_2 \leq 50\text{ms}$
3. $0 < t_3 \leq 1\text{s}$

12. Optical Characteristics

12-1) Specification:

$T_a = 25^\circ\text{C}$

Parameter		Symbol	Condition	MIN.	TYP.	MAX.	Unit	Remarks
Viewing Angle	Horizontal	θ	$CR \geq 10$	75	80	-	deg	Note 12-1
	Vertical	θ (to 6 o'clock)		65	70	-	deg	
		θ (to 12 o'clock)		45	50	-	deg	
Contrast Ratio		CR	At optimized viewing angle	400	600	-	-	Note 12-2
Response time	Rise	T_r	$\theta = 0^\circ$	-	15	30	ms	Note 12-3
	Fall	T_f		-	25	50	ms	
Brightness		-	$\theta = 0^\circ / \varphi = 0$	450	500	-	cd/m^2	Note 12-4
Luminance Uniformity		U%		80	85	-	%	Note 12-5
Cross Talk		-	$\theta = 0^\circ$	-	-	3.5	%	Note 12-7
White Chromaticity		x		0.28	0.31	0.34	-	
		y		0.33	0.36	0.39	-	
Lamp Life Time		-		-	50000	-	hr	$I_L = 5\text{mA}$

Note 12-1: The definitions of viewing angles are as follow

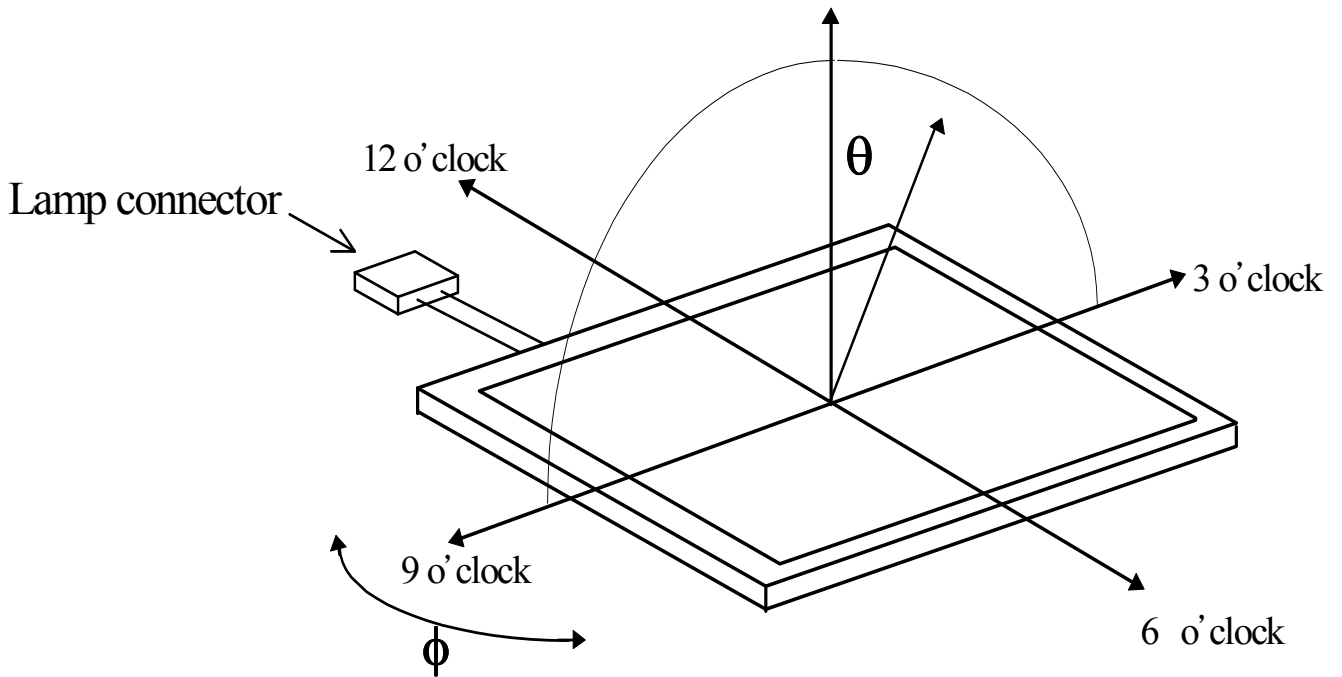

Note 12-2: The definition of contrast ratio $CR = \frac{\text{Luminance at gray level 63}}{\text{Luminance at gray level 0}}$

Note 12-3: Definition of Response Time T_r and T_f :

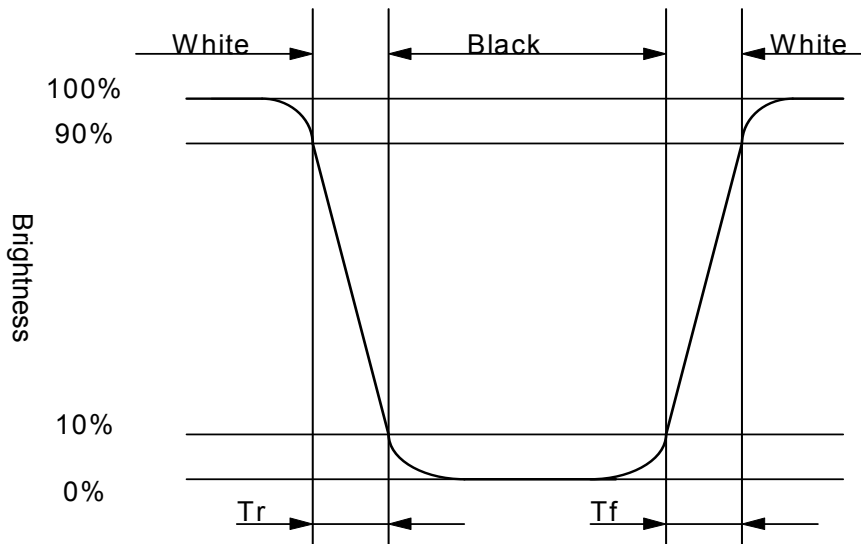

Note 12-4: All optical measurements shall be performed after backlight being turned-on for 30 mins. The optical characteristics shall be measured in dark room (ambient illumination on panel surface less than 1 Lux). The measuring configuration shows as following figure.

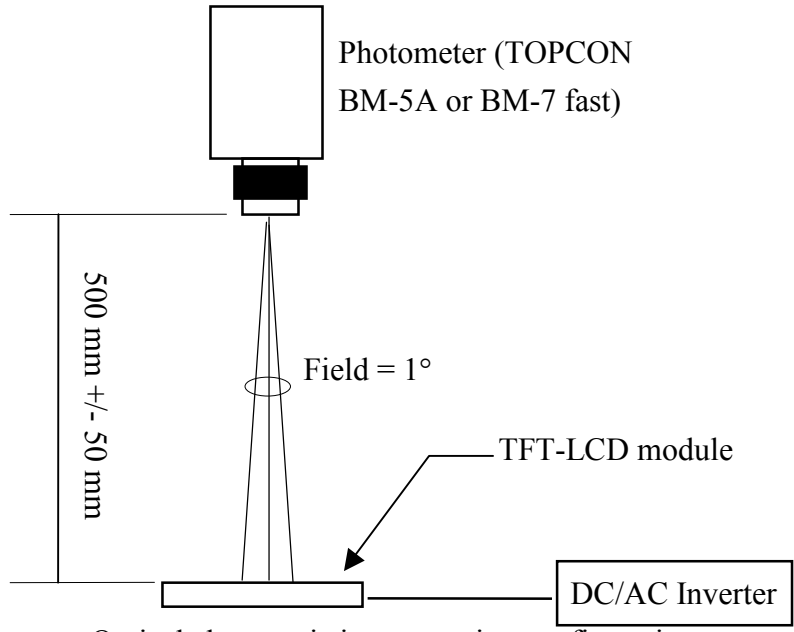

Optical characteristics measuring configuration

Note 12-5: The uniformity of LCD is defined as

$$U = \frac{\text{The Minimum Brightness of the 9 testing Points}}{\text{The Maximum Brightness of the 9 testing Points}}$$

Luminance meter: BM-5A or BM-7 fast (TOPCON)

Measurement distance: 500 mm +/- 50 mm

Ambient illumination: < 1 Lux

Measuring direction: Perpendicular to the surface of module

The test pattern is white (Gray Level 63).

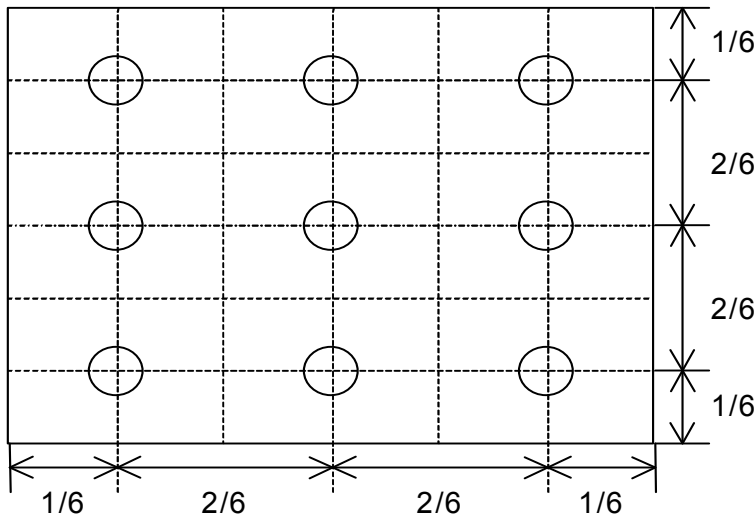

Note 12-7: Cross Talk (CTK) = $\frac{|YA-YB|}{YA} \times 100\%$

YA: Brightness of Pattern A

YB: Brightness of Pattern B

Luminance meter : BM 5A or BM-7 fast (TOPCON)

Measurement distance : 500 mm +/- 50 mm

Ambient illumination : < 1 Lux

Measuring direction : Perpendicular to the surface of module

Pattern A
(Gray Level 31)

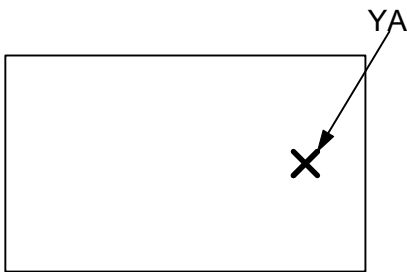

Pattern B
(Gray Level 31, central black box exclusive)

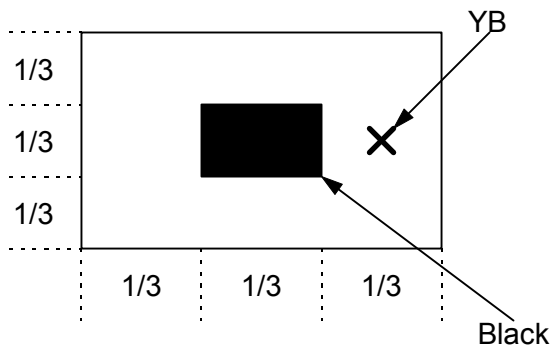

X: Measuring Point (A and B are at the same point.)

Black (Gray Level 0)

13. Handling Cautions

13-1) Mounting of module

- a) Please power off the module when you connect the input/output connector.
- b) Please connect the ground pattern of the inverter circuit surely. If the connection is not perfect, some following problems may happen possibly.
 - 1. The noise from the backlight unit will increase.
 - 2. The output from inverter circuit will be unstable.
 - 3. In some cases a part of module will heat.
- c) Polarizer which is made of soft material and susceptible to flaw must be handled carefully.
- d) Protective film (Laminator) is applied on surface to protect it against scratches and dirt. It is recommended to peel off the laminator before use and taking care of static electricity.

13-2) Precautions in mounting

- a) When metal part of the TFT-LCD module (shielding lid and rear case) is soiled, wipe it with soft dry cloth.
- b) Wipe off water drops or finger grease immediately. Long contact with water may cause discoloration or spots.
- c) TFT-LCD module uses glass which breaks or cracks easily if dropped or bumped on hard surface. Please handle with care.
- d) Since CMOS LSI is used in the module. So take care of static electricity and earth yourself when handling.

13-3) Adjusting module

- a) Adjusting volumes on the rear face of the module have been set optimally before shipment.
- b) Therefore, do not change any adjusted values. If adjusted values are changed, the specifications described may not be satisfied.

13-4) Others

- a) Do not expose the module to direct sunlight or intensive ultraviolet rays for many hours.
- b) Store the module at a room temperature place.
- c) The voltage of beginning electric discharge may over the normal voltage because of leakage current from approach conductor by to draw lump read lead line around.
- d) If LCD panel breaks, it is possibly that the liquid crystal escapes from the panel. Avoid putting it into eyes or mouth. When liquid crystal sticks on hands, clothes or feet. Wash it out immediately with soap.
- e) Observe all other precautionary requirements in handling general electronic components.
- f) Please adjust the voltage of common electrode as material of attachment by 1 module.

13-5) Polarizer mark

The polarizer mark is to describe the direction of wide view angle film how to match up with the rubbing direction.

14. Reliability Test

No	Test Item	Test Condition	Remark
1	High Temperature Storage Test	Ta = +80°C, 240 hrs	
2	Low Temperature Storage Test	Ta = -40°C, 240 hrs	
3	High Temperature Operation Test	Ta = +70°C, 240 hrs	
4	Low Temperature Operation Test	Ta = -30°C, 240 hrs	
5	High Temperature & High Humidity Operation Test	Ta = +60°C, 90%RH, 240 hrs (No Condensation)	
6	Thermal Cycling Test (non-operating)	-20°C → +70°C, 200 Cycles 30 min 30 min	
7	Vibration Test (non-operating)	Frequency: 10 ~ 57 Hz / Vibration Width: 0.075mm 58-500 Hz / Gravity: 9.8m/s ² Sweep time: 11 minutes Test period: 3 hrs for each direction of X, Y, Z	
8	Shock Test (non-operating)	Gravity: 490m/s ² * 6ms Direction: ±X, ±Y, ±Z 3 times for each direction	
9	Electrostatic Discharge Test (non-operating)	150pF · 330Ω Air : ±15KV ; Contact : ±8KV 10 times/point · 9 points/panel face	

Ta: ambient temperature

Note: The protective film must be removed before temperature test

[Criteria]

In the standard conditions, there is not display function NG issue occurred.
(Including : line defect, no image) All the cosmetic specification is judged before the reliability stress.

15. Packing Diagram

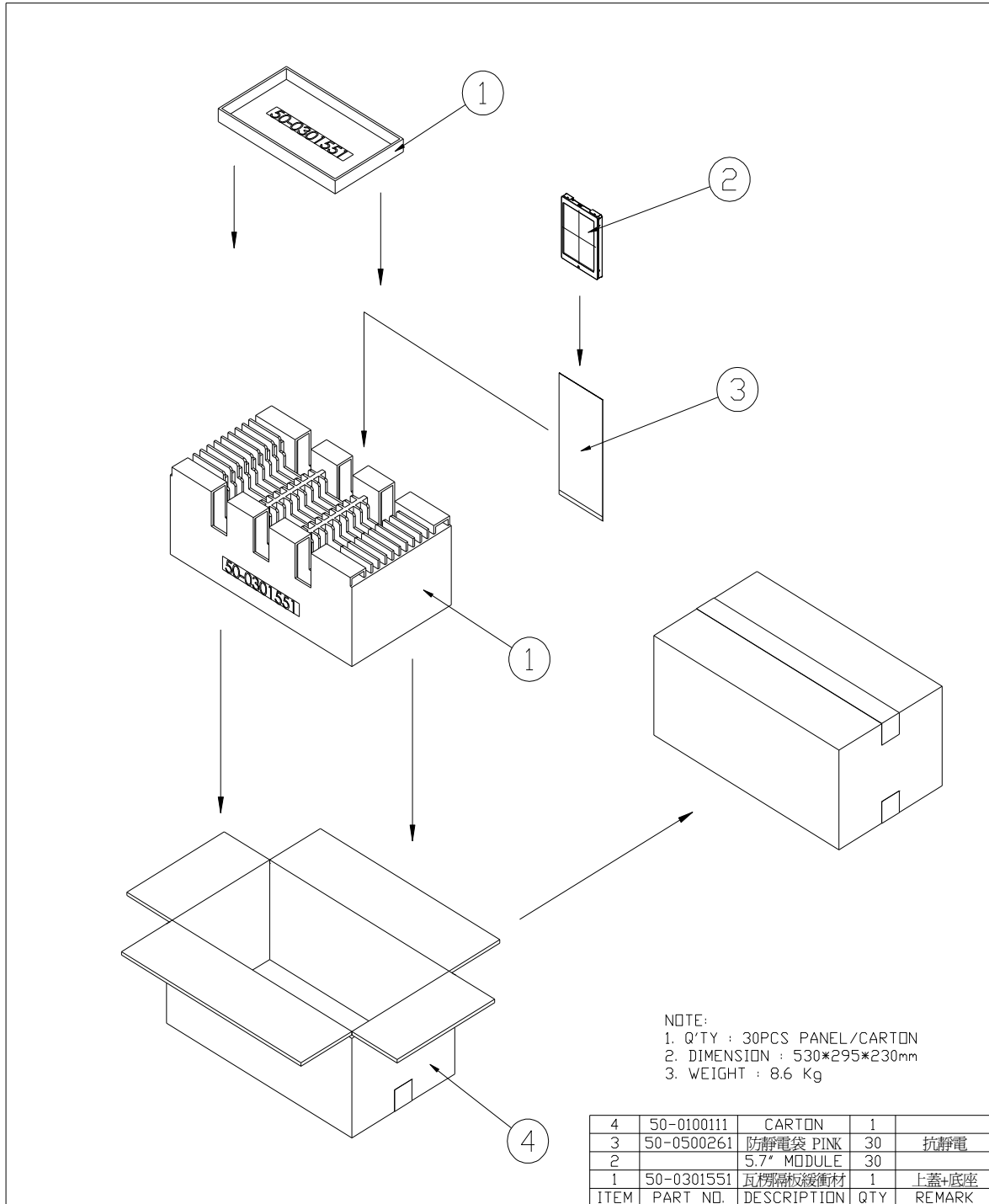

MTL.SPEC.		UNSPECIFIED TOL. ANGLE ROUGHNESS		REMARK		 元太科技股份有限公司 Prime View International Co.,Ltd.	
APPROVE	FRANK SHIN	2007/07/02	SCALE	UNIT	SHEET 1 OF 1	DWG.TITLE 5.7" MODULE PACKING DRAW	
CHECK	FRANK SHIN	2007/07/02	MTL.NO.		PD057VT2	DWG.NO.	REV. 01
DESIGN	JAMES	2007/07/02					A4 SIZE