

TECHNICAL SPECIFICATION

MODEL NO. : PD057VU7











The content of this information is subject to be changed without notice.  
Please contact PVI or its agent for further information.

Customer's Confirmation

Customer \_\_\_\_\_

Date \_\_\_\_\_

By \_\_\_\_\_

Dep	FAE	Panel Design	Electronic Design	Mechanical Design	Product Verification	Prepared by
Sign		 	 	 		 

## Revision History

Rev.	Issued Date	Eng.	Revised	Contents
0.1	Oct, 09, 2007	鄒益智		Preliminary

# TECHNICAL SPECIFICATION

## CONTENTS

<b>NO.</b>	<b>ITEM</b>	<b>PAGE</b>
-	Cover	1
-	Contents	2
-	Revision History	3
1	Application	4
2	Features	4
3	Mechanical Specifications	4
4	Mechanical Drawing of TFT-LCD module	5
5	Input / Output Terminals	6
6	Touch Panel Characteristics	7
7	Absolute Maximum Ratings	8
8	Electrical Characteristics	8
9	Pixel Arrangement	9
10	Display Color and Gray Scale Reference	10
11	Interface Timing	11
12	Power On Sequence	14
13	Optical Characteristics	14
14	Handling Cautions	17
15	Reliability Test	18
16	Packing Diagram	19

## 1. Application

This data sheet applies to a color TFT LCD module, PD057VU7.

PD057VU7 module applies to OA product, car TV (must use Analog to Digital driving board), which requires high quality flat panel display. If you must use in severe reliability environment, please don't extend over PVI's reliability test conditions.

## 2. Features

- . QVGA (320\*240 pixels) resolution
- . Module with resistive type touch panel
- . Amorphous silicon TFT LCD panel with LED
- . Pixel in stripe configuration
- . Thin and light weight
- . Display Colors : 262,144 colors
- . TTL interface

## 3. Mechanical Specifications

Parameter	Specifications	Unit
Screen Size	5.7 (diagonal)	inch
Display Format	320×(R,G,B)×240	dot
Display Colors	262,144	
Active Area	115.20 (H)×86.4 (V)	mm
Pixel Pitch	0.36(H)×0.36(V)	mm
Pixel Configuration	Stripe	
Outline Dimension	144(W)×104.6 (H)×14.45 (D) (typ.)	mm
Weight	245 ± 15	g
Back-light	LED	
Surface treatment	Anti-glare + SWV	
Display mode	Normally white	
Surface treatment of Touch Panel	3H	
Gray scale inversion direction	6 o' clock [ Note 13-1 ]	

**4. Mechanical Drawing of TFT-LCD Module**  
**Outline Drawing : Front View (unit : mm)**

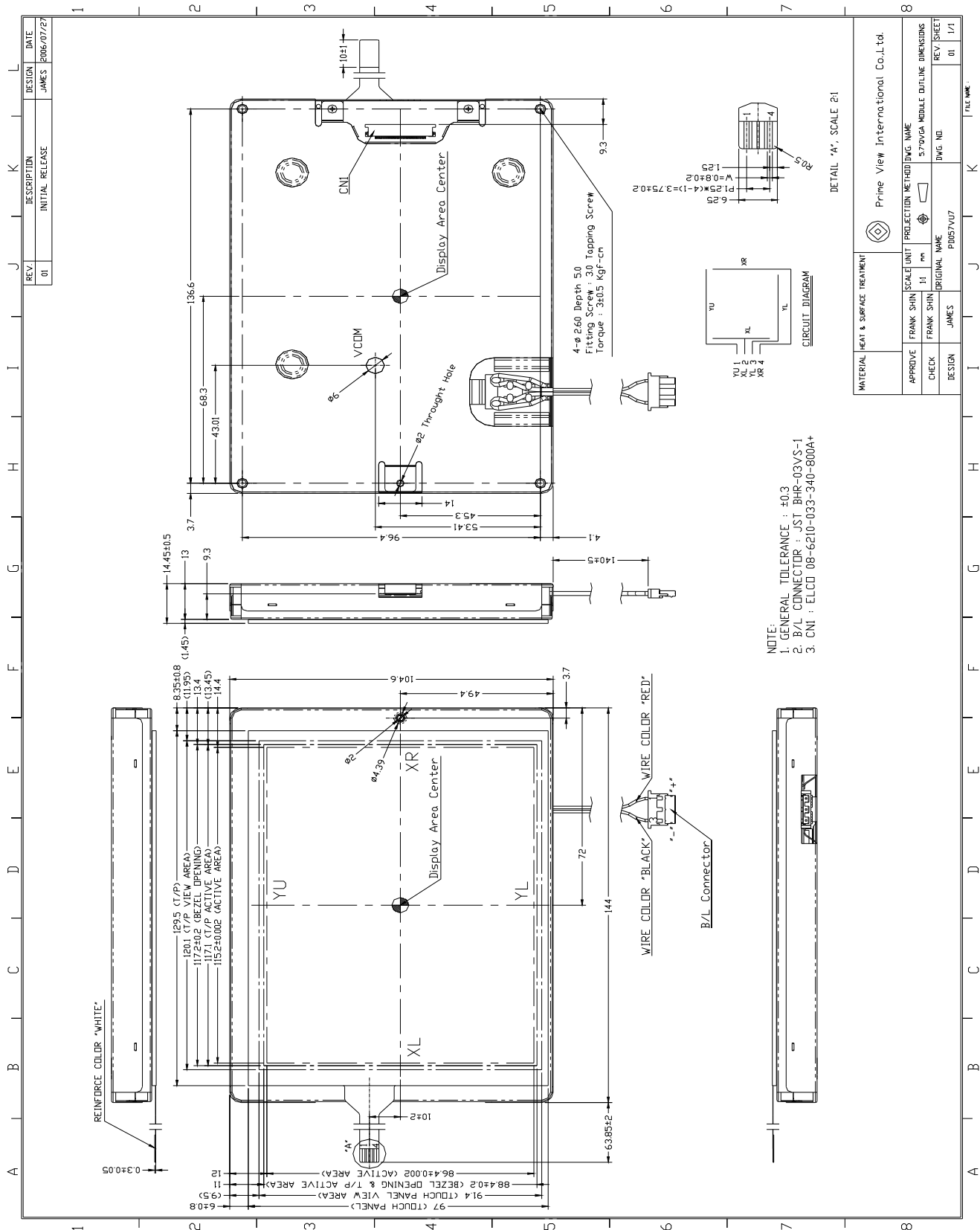

## 5.Input / Output Terminals

### 5-1) TFT-LCD Panel Driving

Connector type: ELCO 08-6210-033-340-800A+ , PIN No 33 pins, pitch=0.5mm

Pin No	Symbol	I/O	Description	Remark
1	GND	-	GND	
2	CK	I	Clock signal for sampling each data signal	
3	Hsync	I	Horizontal synchronous signal(negative)	
4	Vsync	I	Vertical synchronous signal(negative)	
5	GND	-	GND	
6	R0		RED data signal(LSB)	
7	R1	I	RED data signal	
8	R2	I	RED data signal	
9	R3	I	RED data signal	
10	R4	I	RED data signal	
11	R5	I	RED data signal(MSB)	
12	GND	-	GND	
13	G0	I	GREEN data signal(LSB)	
14	G1	I	GREEN data signal	
15	G2	I	GREEN data signal	
16	G3	I	GREEN data signal	
17	G4	I	GREEN data signal	
18	G5	I	GREEN data signal(MSB)	
19	GND	-	GND	
20	B0	I	Blue data signal(LSB)	
21	B1	I	Blue data signal	
22	B2	I	Blue data signal	
23	B3	I	Blue data signal	
24	B4	I	Blue data signal	
25	B5	I	Blue data signal(MSB)	
26	GND	-	GND	
27	ENAB	I	Signal to settle the horizontal display position(positive)	Note5-1
28	V <sub>CC</sub>	-	+ 3.3V power supply	
29	V <sub>CC</sub>	-	+ 3.3V power supply	
30	R/L	I	Horizontal display mode select signal L : Normal ,H : Left /Right reverse mode	Note5-2
31	U/D	I	Vertical display mode select signal H : Normal ,L :Up/Down reverse mode	Note5-3
32	V/Q	I	VGA / QVGA mode select signal	Note11-2
33	GND	-	GND	

Note5-1 : The horizontal display start timing is settled in accordance with rising of ENAB signal. In case ENAB is fixed " Low" ,the horizontal start timing is determined as described in 10-2. Don' t keep ENAB" High" during operation.

Note 5-2 , 5-3 : The definitions of U/D & R/L

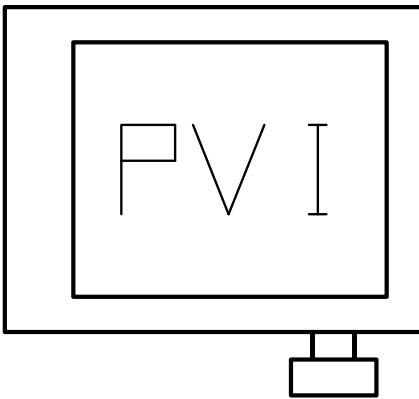

R/L(PIN 30)= Low, U/D(PIN 31)= High

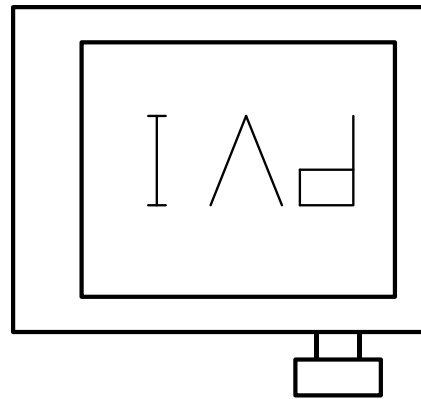

R/L(PIN 30)= High , U/D(PIN 31)= Low

**5-2) LED Backlight driving**

Connector type: JST BHR-03VS-1, PIN No 2 pins, pitch=3.5mm

Pin No	Symbol	Description	Remark
1	+	Input terminal (Anode)	Red
2	NC	No connect	-
3	-	Input terminal (Cathode)	Black

**6. Touch Panel Characteristics**

**6-1) Pin assignment :**

Pin No.	Designation	Remark
1	YU (Bottom)	
2	XL (Top)	
3	YL (Botton)	
4	XR (Top)	

**6-2) Electrical Performance :**

Parameters	Symbol	MIN.	Typ.	MAX.	Unit	Remark
Terminal Resistance	X	400	550	810	$\Omega$	
	Y	230	320	540	$\Omega$	
Input Voltage	VT	-	5	7	V	
Linearity (X ,Y direction)		-	-	$\pm 1.5$	%	
Insulation Impedance		20	-	-	M $\Omega$	DC 25V
Response Time		-	-	15	ms	
Operation Force		-	-	50	g	Note 6-1

Note 6-1 : Input through 0.8R stylus or finger.

**6-3) Durability Performances**

## 1. Hitting Durability :

At least 1,000,000 times with R8.0mm silicon rubber, 250g, 3 times/sec.

## 2. Sliding Durability :

At least 100,000 times with R0.8mm polyacetal stylus, 250g, 60 mm/sec.

**7. Absolute Maximum Ratings:**

GND=0V, Ta=25°C

Parameters	Symbol	Condition	MAX.	Unit	Remark
Input Voltage	$V_I$	Ta=25°C	-0.3~+4	V	Note7-1
+ 3.3V supply voltage	$V_{CC}$	Ta=25°C	0~+ 3.6	V	

Note7-1:CK,R0~R5,G0~G5,B0~B5,Hsync,Vsync,ENAB,R/L,U/D,V/Q

**8. Electrical Characteristics**
**8-1) Recommended Operating Conditions:**

GND=0V, Ta=25°C

Item	Symbol	Min.	Typ.	Max.	Unit	Remark
+ 3.3V Supply Voltage	$V_{CC}$	+ 3.0	+ 3.3	+ 3.6	V	
Permissive input ripple voltage	$V_{RF}$	-	-	100	mVp-p	$V_{CC}=3.3V$
Input voltage(Low)	$V_{IL}$	0	-	0.3 $V_{CC}$	V	
Input voltage(High)	$V_{IH}$	0.7 $V_{CC}$	-	$V_{CC}$	V	

**8-2) Recommended Driving Condition for LED Back Light**

Ta=25°C

Parameter	Symbol	Min.	Typ.	Max.	Unit	Remark
LED voltage	V <sub>LED</sub>	-	11.0	11.5	V	I <sub>L</sub> = 20mA
LED current	I <sub>LED</sub>	-	20	-	mA	Note 8-1
Back Light Power Consumption	P <sub>LED</sub>	-	2640	2760	mW	Note 8-2

Note 8-1 : The LED driving condition is defined for each LED module. (3 LED Serial)

Note 8-2 :  $P_{LED} = V_{LED-1} * I_{LED-1} + V_{LED-2} * I_{LED-2} \dots + V_{LED-11} * I_{LED-11} + V_{LED-12} * I_{LED-12}$

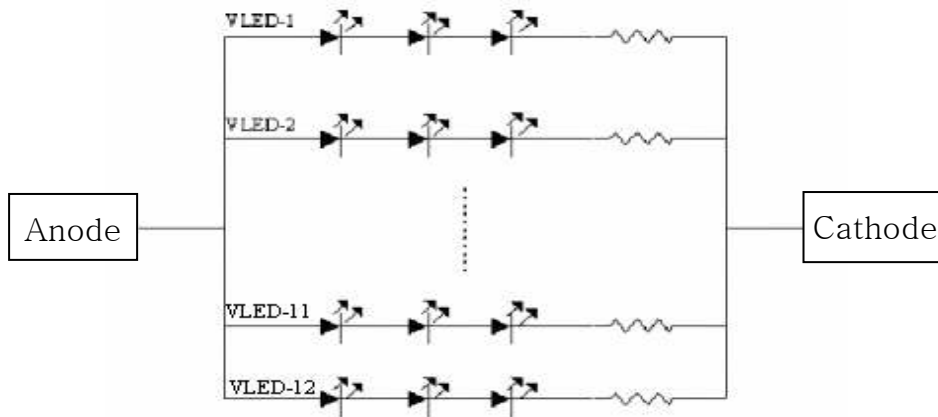

**8-3) Power Consumption**

Parameters	Symbol	Typ.	Max.	Unit	Remark
+ 3.3V Current Dissipation	I <sub>CC</sub>	67	75	mA	
LCD Panel Power Consumption	-	0.22	0.25	W	
Total Power Consumption	-	2.86	3.01	W	

Note 8-3: The power consumption for back light is not included.

**9. Pixel Arrangement**

The LCD module pixel arrangement is stripe configuration.

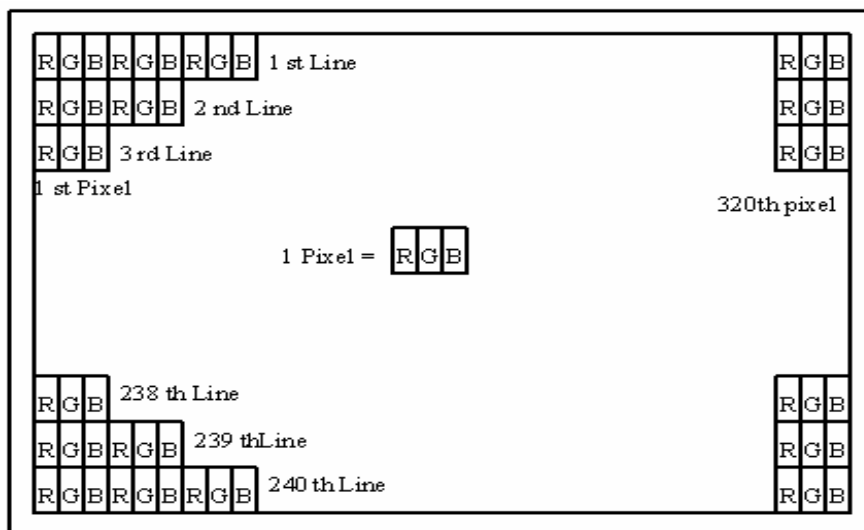

10. Display Color and Gray Scale Reference

Color		Input Color Data																	
		Red						Green						Blue					
		R5	R4	R3	R2	R1	R0	G5	G4	G3	G2	G1	G0	B5	B4	B3	B2	B1	B0
Basic Colors	Black	0	0	0	0	0	0	0	0	0	0	0	0	0	0	0	0	0	0
	Red (63)	1	1	1	1	1	1	0	0	0	0	0	0	0	0	0	0	0	0
	Green (63)	0	0	0	0	0	0	1	1	1	1	1	1	0	0	0	0	0	0
	Blue (63)	0	0	0	0	0	0	0	0	0	0	0	0	1	1	1	1	1	1
	Cyan	0	0	0	0	0	0	1	1	1	1	1	1	1	1	1	1	1	1
	Magenta	1	1	1	1	1	1	0	0	0	0	0	0	1	1	1	1	1	1
	Yellow	1	1	1	1	1	1	1	1	1	1	1	1	0	0	0	0	0	0
	White	1	1	1	1	1	1	1	1	1	1	1	1	1	1	1	1	1	1
Red	Red (00)	0	0	0	0	0	0	0	0	0	0	0	0	0	0	0	0	0	0
	Red (01)	0	0	0	0	0	1	0	0	0	0	0	0	0	0	0	0	0	0
	Red (02)	0	0	0	0	1	0	0	0	0	0	0	0	0	0	0	0	0	0
	Darker																		
	↓	↓	↓	↓	↓	↓	↓	↓	↓	↓	↓	↓	↓	↓	↓	↓	↓	↓	↓
	Brighter																		
	Red (61)	1	1	1	1	0	1	0	0	0	0	0	0	0	0	0	0	0	0
	Red (62)	1	1	1	1	1	0	0	0	0	0	0	0	0	0	0	0	0	0
Red (63)	1	1	1	1	1	1	0	0	0	0	0	0	0	0	0	0	0	0	
Green	Green (00)	0	0	0	0	0	0	0	0	0	0	0	0	0	0	0	0	0	0
	Green (01)	0	0	0	0	0	0	0	0	0	0	0	1	0	0	0	0	0	0
	Green (02)	0	0	0	0	0	0	0	0	0	0	1	0	0	0	0	0	0	0
	Darker																		
	↓	↓	↓	↓	↓	↓	↓	↓	↓	↓	↓	↓	↓	↓	↓	↓	↓	↓	↓
	Brighter																		
	Green (61)	0	0	0	0	0	0	1	1	1	1	0	1	0	0	0	0	0	0
	Green (62)	0	0	0	0	0	0	1	1	1	1	1	0	0	0	0	0	0	0
Green (63)	0	0	0	0	0	0	1	1	1	1	1	1	0	0	0	0	0	0	
Blue	Blue (00)	0	0	0	0	0	0	0	0	0	0	0	0	0	0	0	0	0	0
	Blue (01)	0	0	0	0	0	0	0	0	0	0	0	0	0	0	0	0	0	1
	Blue (02)	0	0	0	0	0	0	0	0	0	0	0	0	0	0	0	0	1	0
	Darker																		
	↓	↓	↓	↓	↓	↓	↓	↓	↓	↓	↓	↓	↓	↓	↓	↓	↓	↓	↓
	Brighter																		
	Blue (61)	0	0	0	0	0	0	0	0	0	0	0	0	1	1	1	1	0	1
	Blue (62)	0	0	0	0	0	0	0	0	0	0	0	0	1	1	1	1	1	0
Blue (63)	0	0	0	0	0	0	0	0	0	0	0	0	1	1	1	1	1	1	

## 11. Interface Timing

### 11-1) Timing Parameters

AC Electrical Characteristics ( $V_{CC} = +3.3V, GND=0V, T_a=25^{\circ}C$ )

Characteristics		Symbol	Min.	Typ.	Max.	Unit	Remark
Clock	Frequency	1/Tc	-	25.18	28.33	MHz	V/Q=H
			-	6.3	7.0	MHz	V/Q=L
	Duty ratio	Tch/Tc	40	50	60	%	V/Q=L
Data	Set up time	Tds	5	-	-	ns	
	Hold time	Tdh	10	-	-		
Horizontal sync. signal	Cycle	TH	30.0	31.8	-	us	V/Q=H
			700	800	900	clock	
		TH	50.0	63.6	-	us	V/Q=L
			360	400	450	clock	
Pulse width	THp	2	96	200	clock		
Vertical sync. signal	Cycle	TV	515	525	560	line	V/Q=H
		TV	251	262	280		V/Q=L
	Pulse width	TVp	2	-	34	line	
Horizontal display period		THd	320			Clock	
Hsync.-Clock phase difference		THc	10	-	Tc-10	ns	
Hsync.-Vsync. phase difference		TVh	0	-	TH-THp	ns	
Vertical sync. signal start position		TVs	34			line	V/Q=H
			7				V/Q=L

Note11-1 : In case of lower frequency, the deterioration of the display quality, flicker etc., May be occurred.

Parameter		symbol	Min.	Typ	Max	Unit	Remark
Enable signal	Set up time	Tes	5	-	Tc-10	ns	
	Pulse width	Tep	2	320	TH-10	clock	
Hsync-Enable signal phase difference		The	44	-	TH-664	clock	V/Q=H
			2	-	TH-340		V/Q=L

Note11-2 :

When ENAB is fixed at "V/Q=Low", the display starts from the data of C52 (clock).

When ENAB is fixed at "V/Q=High", the display starts from the data of C104 (clock).

11-2) Timing Diagram

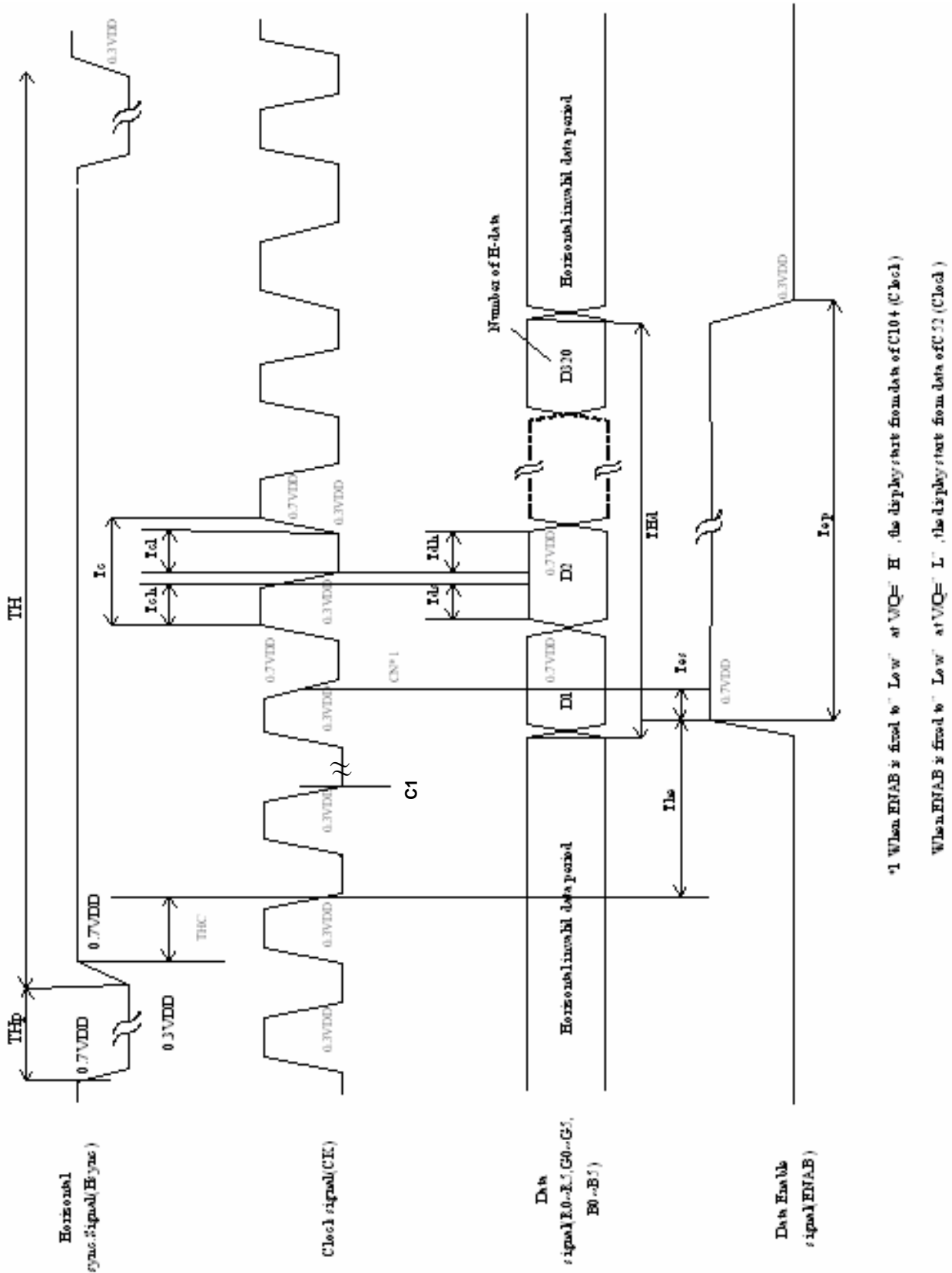

\*1 When ENAB is fired to 'Low' at VCC=H, the display start from data of C10+ (Clock)  
 When ENAB is fired to 'Low' at VCC=L, the display start from data of C52 (Clock)

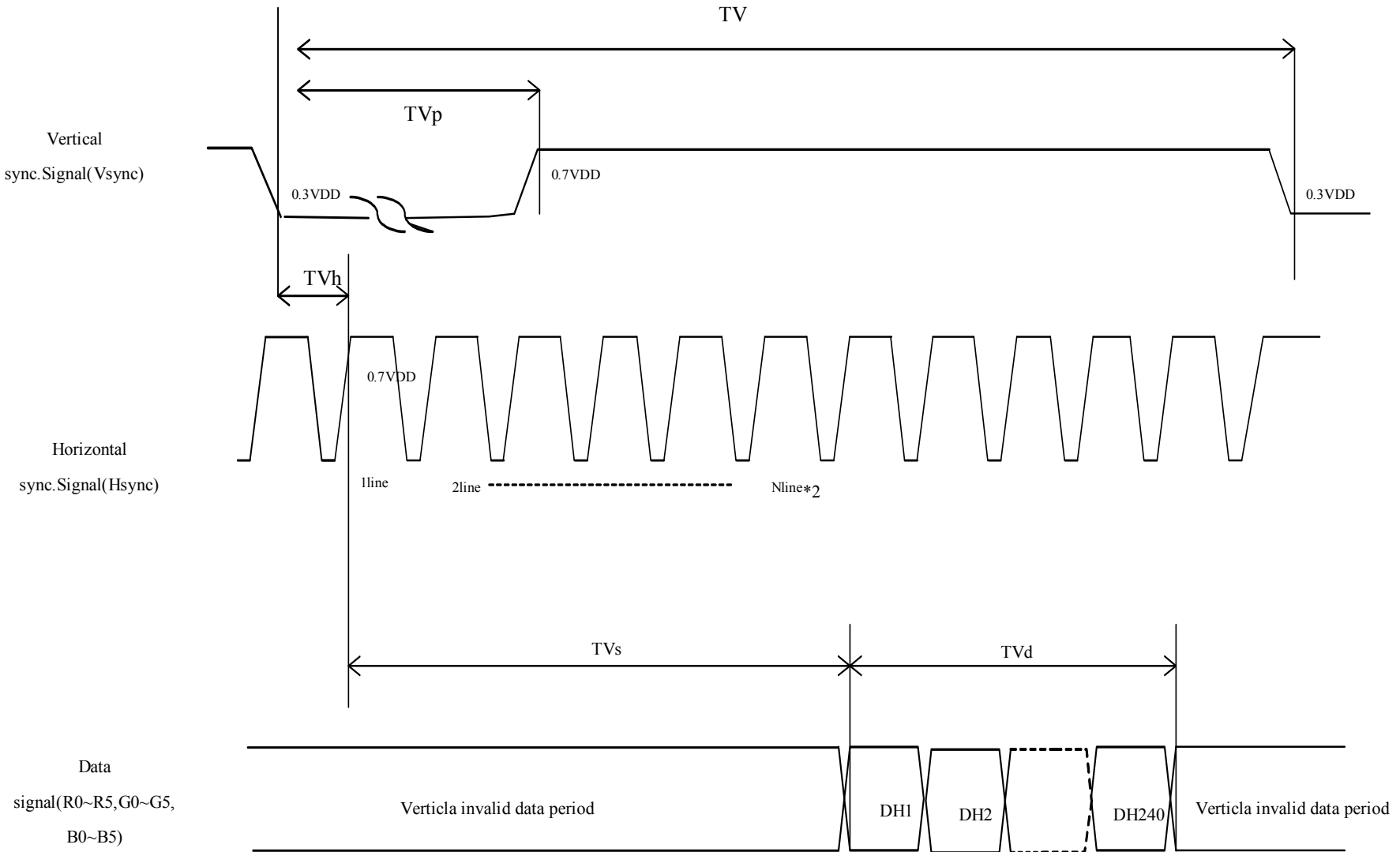

\*2 The vertical display position (TVs) is fixed at 34th line (V/Q=H) and 7th line (V/Q=L).

**12. Power On Sequence**

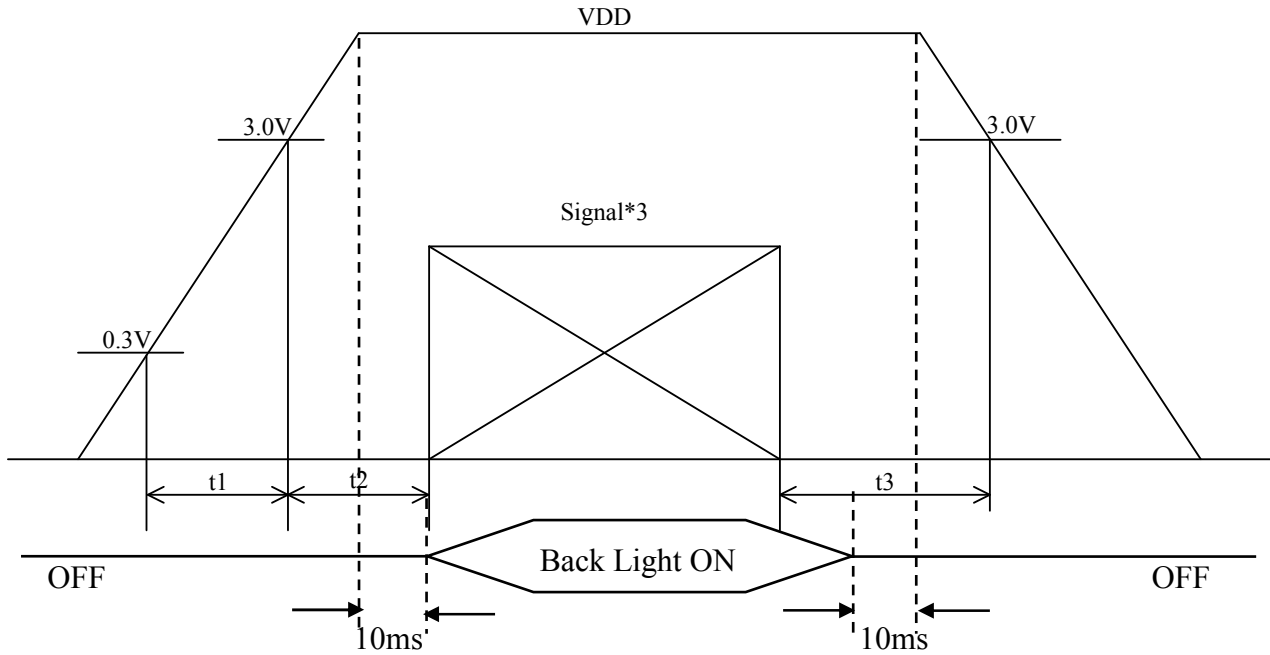

1.  $0 < t_1 \leq 20\text{ms}$
2.  $0 < t_2 \leq 50\text{ms}$
3.  $0 < t_3 \leq 1\text{s}$

**13. Optical Characteristics**

**13-1) Specification:**

$T_a = 25^\circ\text{C}$

Parameter		Symbol	Condition	MIN.	TYP.	MAX.	Unit	Remarks
Viewing Angle	Horizontal	$\theta$	$CR \geq 10$	55	60	-	deg	Note 13-1
	Vertical	$\theta$ (to 6 o'clock)		45	50	-	deg	
		$\theta$ (to 12 o'clock)		35	40	-	deg	
Contrast Ratio		CR	At optimized viewing angle	<b>300</b>	<b>600</b>	-	-	Note 13-2
Response time	Rise	$T_r$	$\theta = 0^\circ$	-	15	30	ms	Note 13-3
	Fall	$T_f$		-	25	50	ms	
Brightness		-	$\theta = 0^\circ / \phi = 0$	<b>550</b>	<b>650</b>	-	$\text{cd/m}^2$	Note 13-4
Luminance Uniformity		U%		80	85	-	%	Note 13-5
White Chromaticity		x		0.28	0.31	0.34	-	
		y		0.31	0.34	0.37	-	
LED Life Time		-		20000	-	-	hr	

Note 13-1: The definitions of viewing angles are as follow

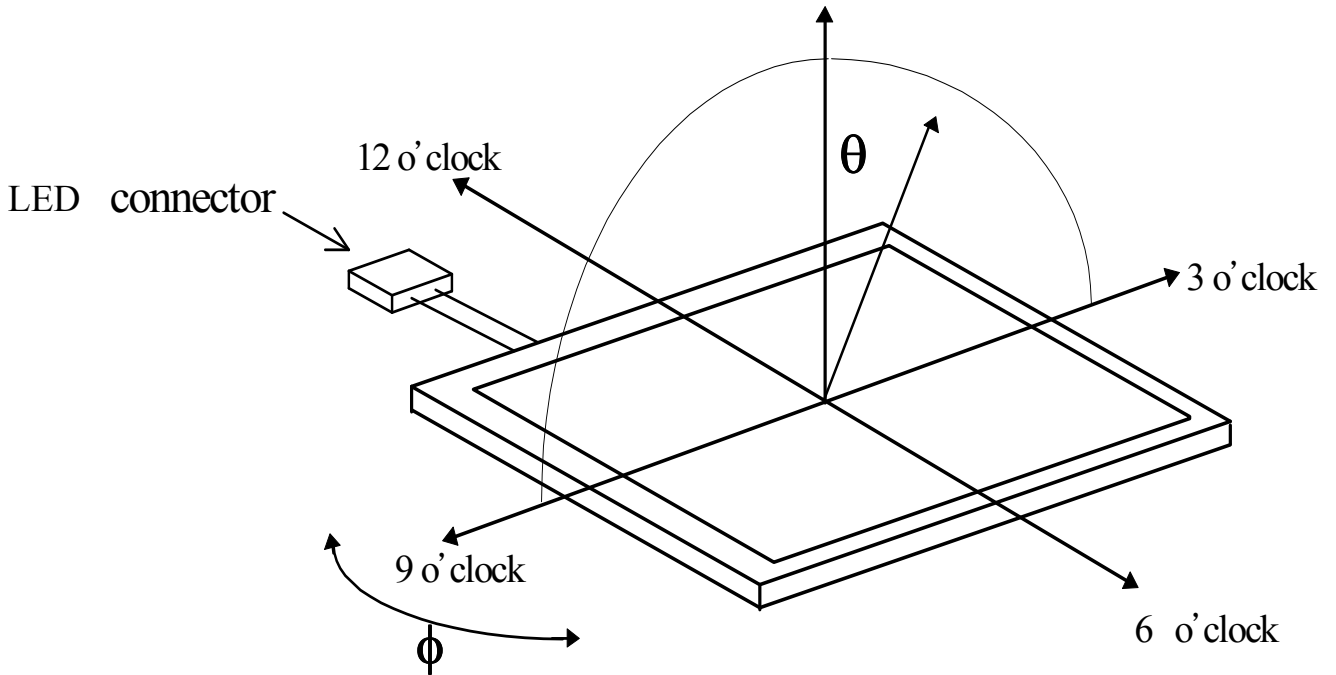

Note 13-2: The definition of contrast ratio  $CR = \frac{\text{Luminance at gray level 63}}{\text{Luminance at gray level 0}}$

Note 13-3: Definition of Response Time  $T_r$  and  $T_f$ :

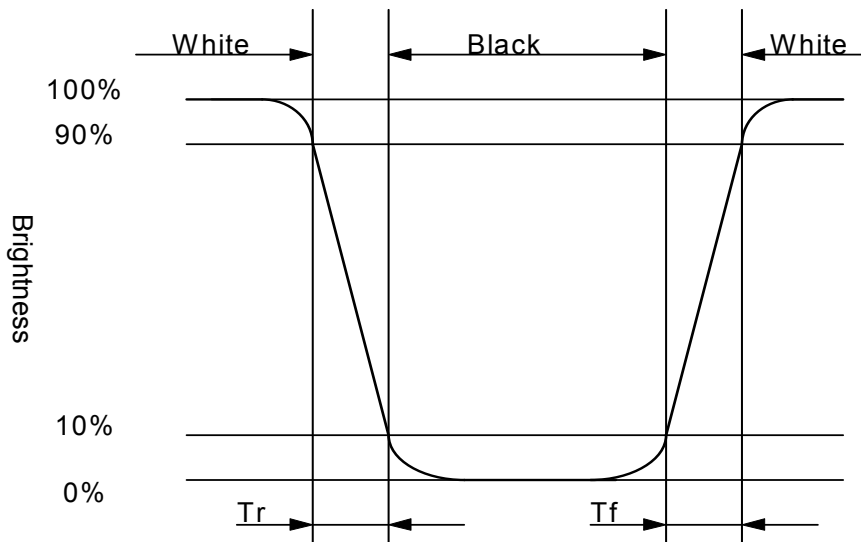

Note 13-4: The optical characteristics shall be measured in dark room (ambient illumination on panel surface less than 1 Lux). The measuring configuration shows as following figure.

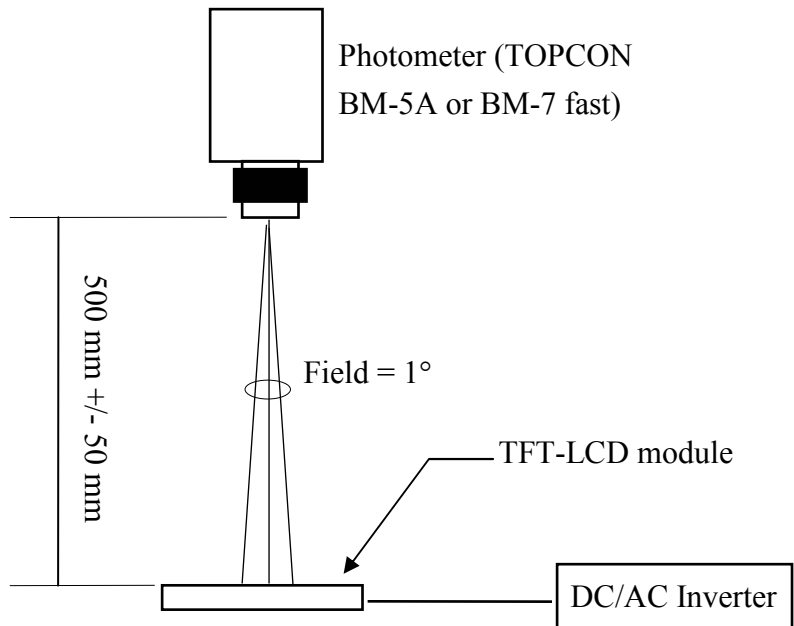

Optical characteristics measuring configuration

Note 13-5: The uniformity of LCD is defined as

$$U = \frac{\text{The Minimum Brightness of the 9 testing Points}}{\text{The Maximum Brightness of the 9 testing Points}}$$

Luminance meter: BM-5A or BM-7 fast (TOPCON)

Measurement distance: 500 mm +/- 50 mm

Ambient illumination: < 1 Lux

Measuring direction: Perpendicular to the surface of module

The test pattern is white (Gray Level 63).

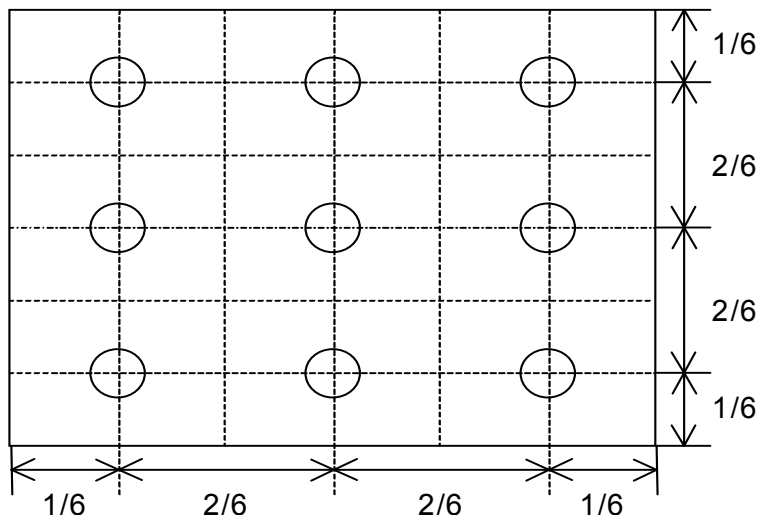

## 14. Handling Cautions

### 14-1) Mounting of module

- a) Please power off the module when you connect the input/output connector.
- b) Polarizer which is made of soft material and susceptible to flaw must be handled carefully.
- c) Protective film (Laminator) is applied on surface to protect it against scratches and dirt. It is recommended to peel off the laminator before use and taking care of static electricity.

### 14-2) Precautions in mounting

- a) When metal part of the TFT-LCD module (shielding lid and rear case) is soiled, wipe it with soft dry cloth.
- b) Wipe off water drops or finger grease immediately. Long contact with water may cause discoloration or spots.
- c) TFT-LCD module uses glass which breaks or cracks easily if dropped or bumped on hard surface. Please handle with care.
- d) Since CMOS LSI is used in the module. So take care of static electricity and earth yourself when handling.

### 14-3) Adjusting module

- a) Adjusting volumes on the rear face of the module have been set optimally before shipment.
- b) Therefore, do not change any adjusted values. If adjusted values are changed, the specifications described may not be satisfied.

### 14-4) Others

- a) Do not expose the module to direct sunlight or intensive ultraviolet rays for many hours.
- b) Store the module at a room temperature place.
- c) The voltage of beginning electric discharge may over the normal voltage because of leakage current from approach conductor by to draw lump read lead line around.
- d) If LCD panel breaks, it is possibly that the liquid crystal escapes from the panel. Avoid putting it into eyes or mouth. When liquid crystal sticks on hands, clothes or feet. Wash it out immediately with soap.
- e) Observe all other precautionary requirements in handling general electronic components.
- f) Please adjust the voltage of common electrode as material of attachment by 1 module.

### 14-5) Polarizer mark

The polarizer mark is to describe the direction of wide view angle film how to match up with the rubbing direction.

**15. Reliability Test**

No	Test Item	Test Condition	Remark
1	High Temperature Storage Test	Ta = + 85℃, 240 hrs	
2	Low Temperature Storage Test	Ta = -40℃, 240 hrs	
3	High Temperature Operation Test	Ta = + 80℃, 240 hrs	
4	Low Temperature Operation Test	Ta = -30℃, 240 hrs	
5	High Temperature & High Humidity Operation Test	Ta = + 60℃, 90%RH, 240 hrs (No Condensation)	
6	Thermal Cycling Test (non-operating)	-20℃ → + 70℃, 200 Cycles 30 min 30 min	
7	Vibration Test (non-operating)	Frequency: 10 ~ 57 HZ /Vibration Width:0.075 mm 58-500 Hz / Gravity: 9.8m/s <sup>2</sup> Sweep time: 11 minutes Test period: 3 hrs for each direction of X, Y, Z	
8	Shock Test (non-operating)	Gravity: 490m/s <sup>2</sup> * 6ms Direction: ±X, ±Y, ±Z 3 times for each direction	
9	Electrostatic Discharge Test (non-operating)	Machine Mode = ±200V C = 200pF , R = 0Ω 1 times discharge for each pad	
10	Hitting Durability Test (Touch panel)	1,000,000 times, with R 8.0 mm silicon rubber, 250g, 3times/sec	
11	Sliding Durability Test (Touch panel)	1,00,000 times, with R 0.8 mm polyacetal stylus, 250g, 60mm/sec	

Ta: ambient temperature

Note: The protective film must be removed before temperature test

[Criteria]

In the standard conditions, there is not display function NG issue occurred. (Including : line defect, no image) All the cosmetic specification is judged before the reliability stress.

16. Packing Diagram

TBD