

Version: 2.0

<p style="text-align: center;">TECHNICAL SPECIFICATION</p> <p style="text-align: center;">MODEL NO : PD104SLG</p>
---

The content of this information is subject to be changed without notice.  
Please contact PVI or its agent for further information.

Customer's Confirmation

Customer \_\_\_\_\_

Date \_\_\_\_\_

By \_\_\_\_\_

PVI's Confirmation

  
Confirmed By \_\_\_\_\_

  
Prepared By \_\_\_\_\_

---

## Revision History

Rev.	Issued Date	Eng.	Revised Content
1.0	July , 29 , 2008	李穎銘	NEW
2.0	Aug , 20 , 2008	李穎銘	Page 7 5.Input Terminals Modify Connector Pin from 20-pin to 14-pin Page 9 6.Absolute Maximum Ratings Delete Input Signals Voltage Page 11 7-4) Input / Output signal timing chart Modify Timing chart

---

**TECHNICAL SPECIFICATION****CONTENTS**

<b><i>NO.</i></b>	<b><i>ITEM</i></b>	<b><i>PAGE</i></b>
-	Cover	1
-	Revision History	2
-	Contents	3
1	Application	4
2	Features	4
3	Mechanical Specifications	4
4	Mechanical Drawing of TFT-LCD module	5
5	Input Terminals	7
6	Absolute Maximum Ratings	9
7	Electrical Characteristics	9
8	Power On Sequence	15
9	Optical Characteristics	16
10	Handling Cautions	19
11	Reliability Test	20
12	Block Diagram	21
13	Packing	22

### 1.Application

This data sheet applies to a color TFT LCD module, PD104SLG.  
 PD104SLG module applies to OA product, car TV(must use Analog to Digital drive board), which require high quality flat panel display. If you must use in high reliability environment can't over reliability test condition  
 Prime View assume no responsibility for any damage resulting from the use of the device which dose not comply with the instructions and the precautions in these specification sheet.

### 2. Features

- . Amorphous silicon TFT LCD panel with High Brightness LED back-light unit
- . Pixel in stripe configuration
- . Slim and compact, designed for O/A application
- . Display Colors : 262,144 colors
- . +3.3V DC supply voltage for TFT LCD panel driving
- . Wide Viewing Angle

### 3.Mechanical Specifications

Parameter	Specifications	Unit
Screen Size	10.4 (diagonal)	inch
Display Format	800×(R, G, B)×600	dot
Display Colors	262,144	
Active Area	211.2(H)×158.4 (V)	mm
Pixel Pitch	0.264 (H)×0.264 (V)	mm
Pixel Configuration	Stripe	
Outline Dimension	243.0 (w)×185.1(H)×10.5(typ.) (D)	mm
Weight	470±20	g
Back-light	28-middle power LED	
Surface treatment	Anti-glare and EWV	
Display mode	Normally white	
Gray scale inversion direction	12 o'clock [ ref to Note 9-1 ]	

4. Mechanical Drawing of TFT-LCD Module

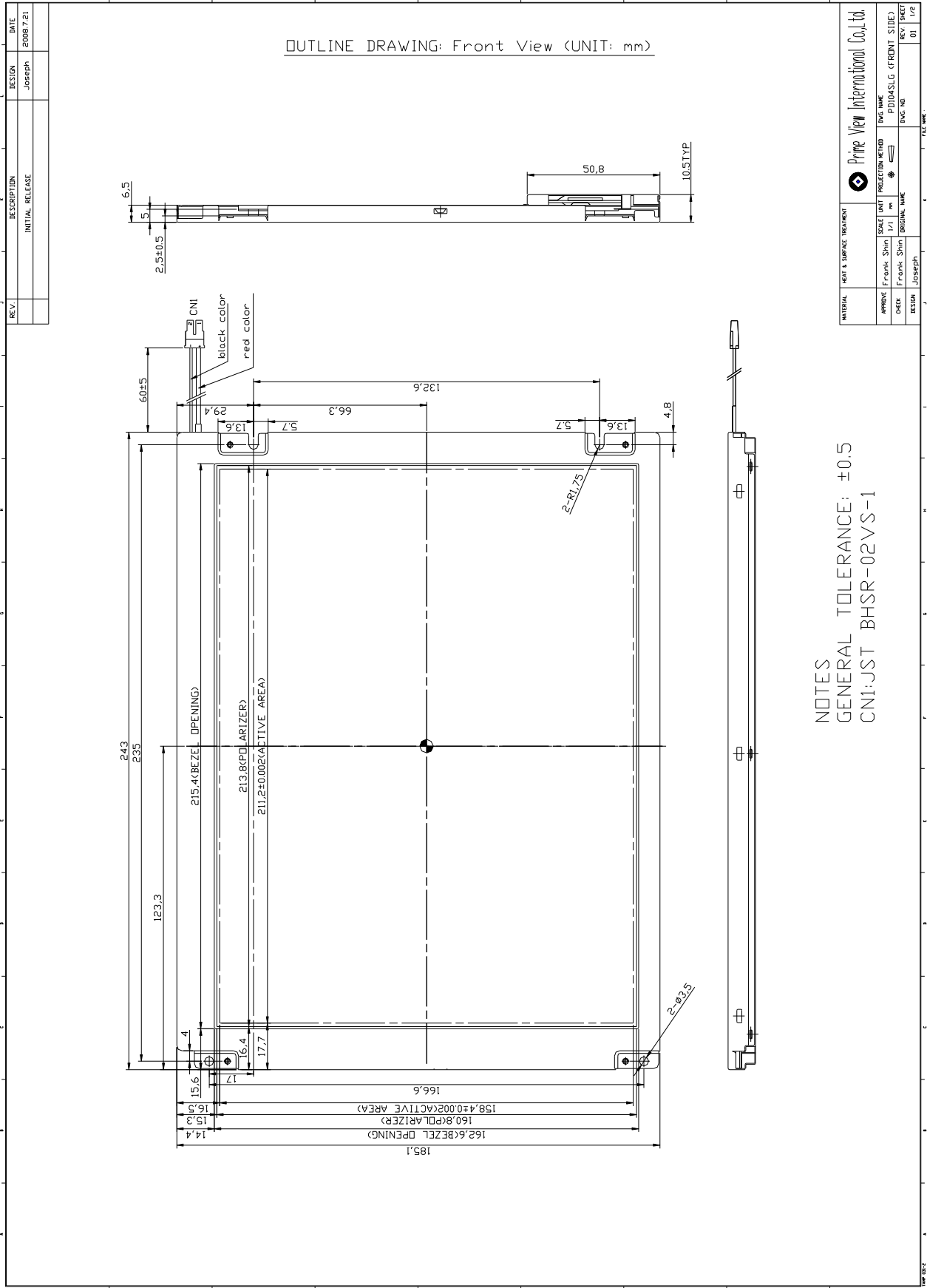

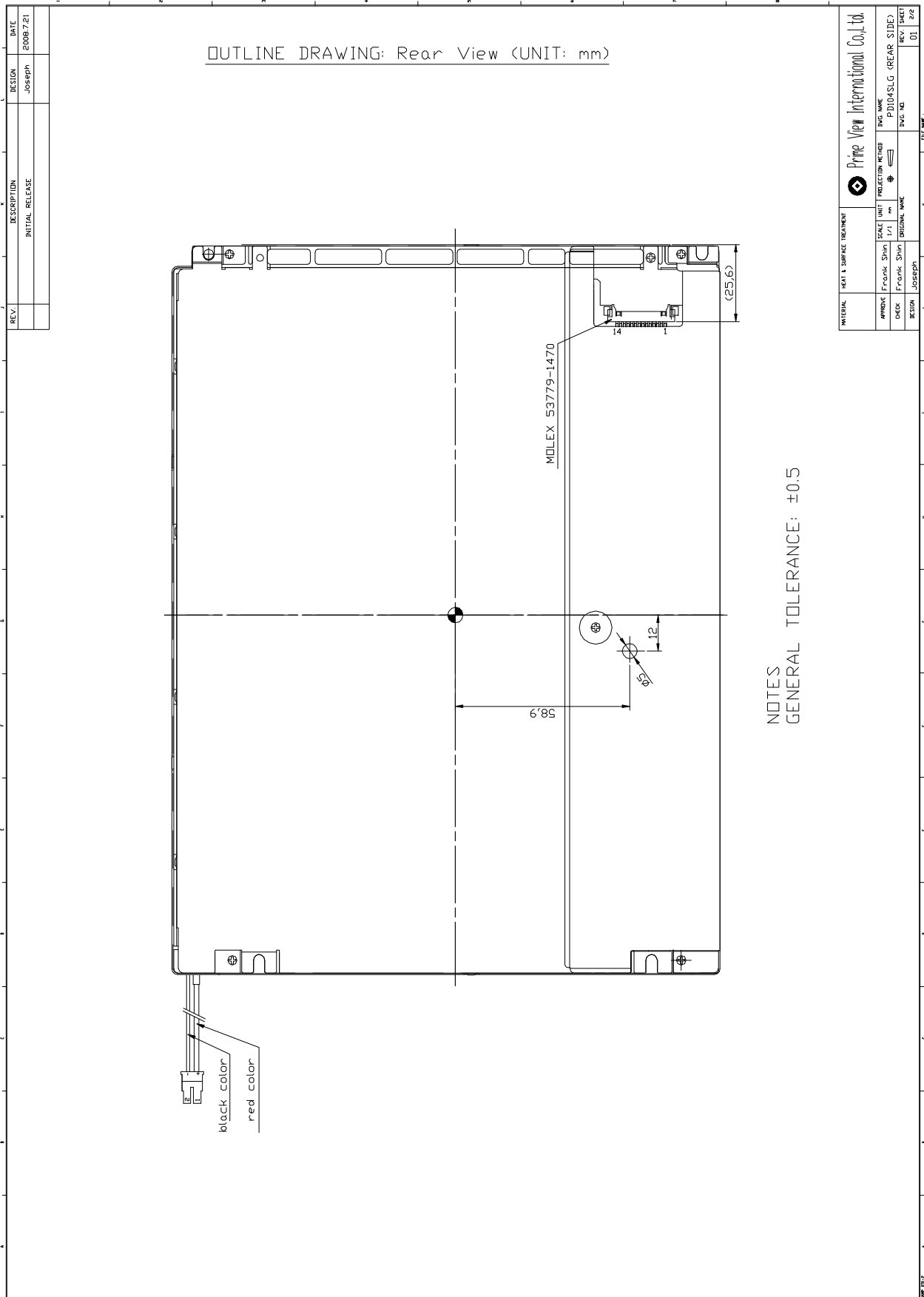

## 5. Input Terminals

### 5-1) TFT-LCD Panel Driving

Connector type: Molex 53779-1470

<b>Pin No.</b>	<b>Symbol</b>	<b>Function</b>	<b>Remark</b>
1	VDD	Power supply : +3.3V	
2	VDD	Power supply : +3.3V	
3	GND	Ground	
4	GND	Ground	
5	IN0-	Pixel data Transmission pair 0 (negative -)	
6	IN0+	Pixel data Transmission pair 0 (positive +)	
7	IN1-	Pixel data Transmission pair 1 (negative -)	
8	IN1+	Pixel data Transmission pair 1 (positive +)	
9	IN2-	Pixel data Transmission pair 2 (negative -)	
10	IN2+	Pixel data Transmission pair 2 (positive +)	
11	CLK-	Sampling Clock (negative -)	
12	CLK+	Sampling Clock (positive +)	
13	GND	Ground	
14	GND	Ground	

Recommended Transmitter (THC63LVDM63A Thine) to PD104SLG interface Assignment :

Input terminal of THC63LVDM63A		Graphic controller output signal		Output signal symbol	To PD104SLG interface terminal(Symbol)
Symbol	No.	Symbol	Function		
TIN0	44	R0	Red pixel data (LSB)	Tout0- Tout0+	No.5 : IN0- No.6 : IN0+
TIN1	45	R1	Red pixel data		
TIN2	47	R2	Red pixel data		
TIN3	48	R3	Red pixel data		
TIN4	1	R4	Red pixel data		
TIN5	3	R5	Red pixel data(MSB)	Tout1- Tout1+	No.7 : IN1- No.8 : IN1+
TIN6	4	G0	Green pixel data (LSB)		
TIN7	6	G1	Green pixel data		
TIN8	7	G2	Green pixel data		
TIN9	9	G3	Green pixel data		
TIN10	10	G4	Green pixel data	Tout2- Tout2+	No.9 : IN2- No.10 : IN2+
TIN11	12	G5	Green pixel data(MSB)		
TIN12	13	B0	Blue pixel data(LSB)		
TIN13	15	B1	Blue pixel data		
TIN14	16	B2	Blue pixel data		
TIN15	18	B3	Blue pixel data	TCLK out- TCLK out+	No.11 : CLK - No.12 : CLK +
TIN16	19	B4	Blue pixel data		
TIN17	20	B5	Blue pixel data(MSB)		
TIN18	22	HSYNC	Horizontal sync signal		
TIN19	23	VSYSN	Vertical sync signal		
TIN20	25	DENB	Compound Synchronization signal		
TCLK in	26	CLK	Data sampling clock		

Data stream of IN0-/+ , IN1-/+ and IN2-/+ for PD104SLG

LVDS Interface Block Diagram

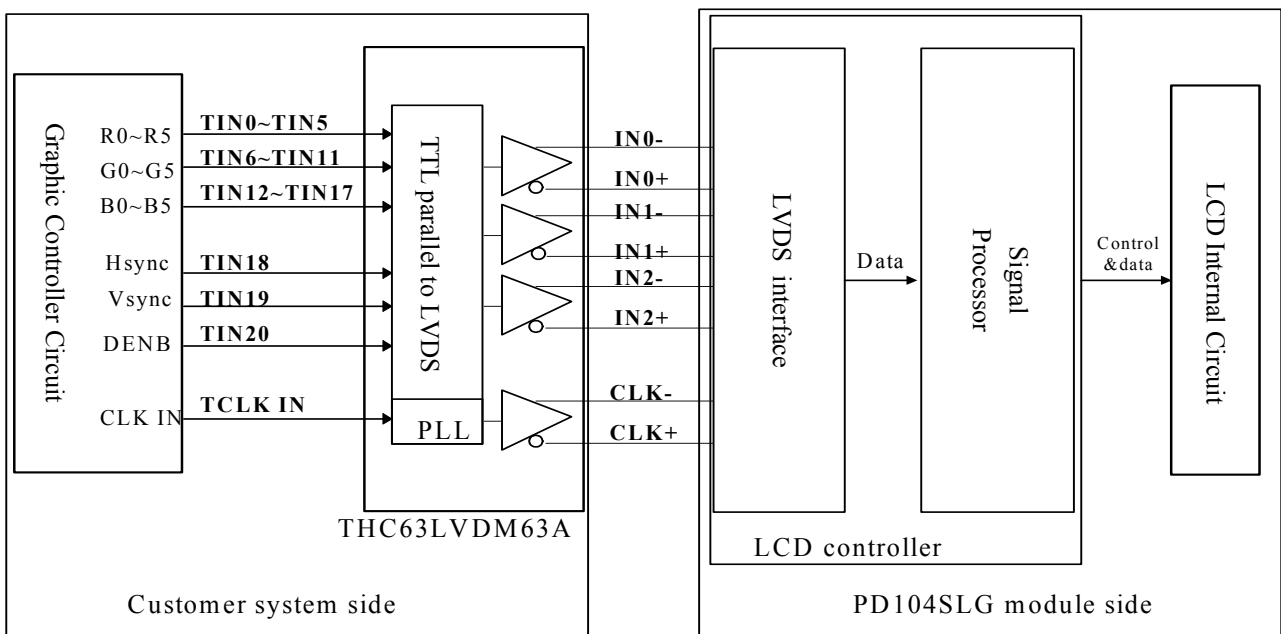

5-2) Backlight driving

Connector type : "BHSR-02VS-1" of Japan Solderless Terminal MFG Co. LTD

Pin No	Symbol	Description	Remark
1	+	Input terminal (Anode)	Wire color : Red
2	-	Input terminal (Cathode)	Wire Color : Black

6.Absolute Maximum Ratings:

GND=0V, Ta=25°C

Parameters	Symbol	MIN.	MAX.	Unit	Remark
Supply Voltage	V <sub>DD</sub>	-0.3	+4.0	V	

7.Electrical Characteristics

7-1) Recommended Operating Conditions:

GND = 0V , Ta = 25°C

Item	Symbol	Min.	Typ.	Max.	Unit	Remark
Supply Voltage	VDD	3.0	3.3	3.6	V	
Current Dissipation	I <sub>DD</sub>	-	190	380	mA	Note 7-1
LVDS Differential input high threshold	V <sub>TH</sub>	-	-	100	mV	Note 7-2
LVDS Differential input low threshold	V <sub>TL</sub>	-100	-	-		

Note 7-1 : To test the current dissipation of VDD, using the "color bars" testing pattern shown as below

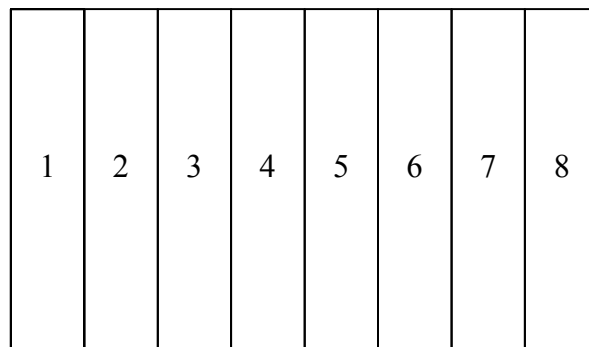

1. White
2. Yellow
3. Cyan
4. Green
5. Magenta
6. Red
7. Blue
8. Black

I<sub>DD</sub> current dissipation testing pattern

Note 7-2 :Please refers to THC63LVDF63A specification by THINE Corporation. This LCD module conforms to LVDS standard.

7-2) Recommended Driving Condition for Back Light

Ta = 25°C

Parameter	Symbol	Min	TYP	MAX	Unit	Remark
Supply voltage of LED backlight	V <sub>LED</sub>	-	-	(14)	V	Note 7-3
Supply current of LED backlight	I <sub>LED</sub>	-	120	-	mA	Note 7-4
Backlight Power Consumption	P <sub>LED</sub>	-	-	11.76	W	Note 7-3 / Note 7-5

Note 7-3 : I<sub>LED</sub> = 120mA(Constant Current).

Note 7-4 : The LED driving condition is defined for each LED module. (4 LED Serial)

$$\text{Input current} = 120\text{mA} * 7 = 840\text{mA}$$

$$\text{Note 7-5 : } P_{LED} = V_{LED-1} * I_{LED-1} + V_{LED-2} * I_{LED-2} \dots + V_{LED-7} * I_{LED-7} + V_{LED-7} * I_{LED-7}$$

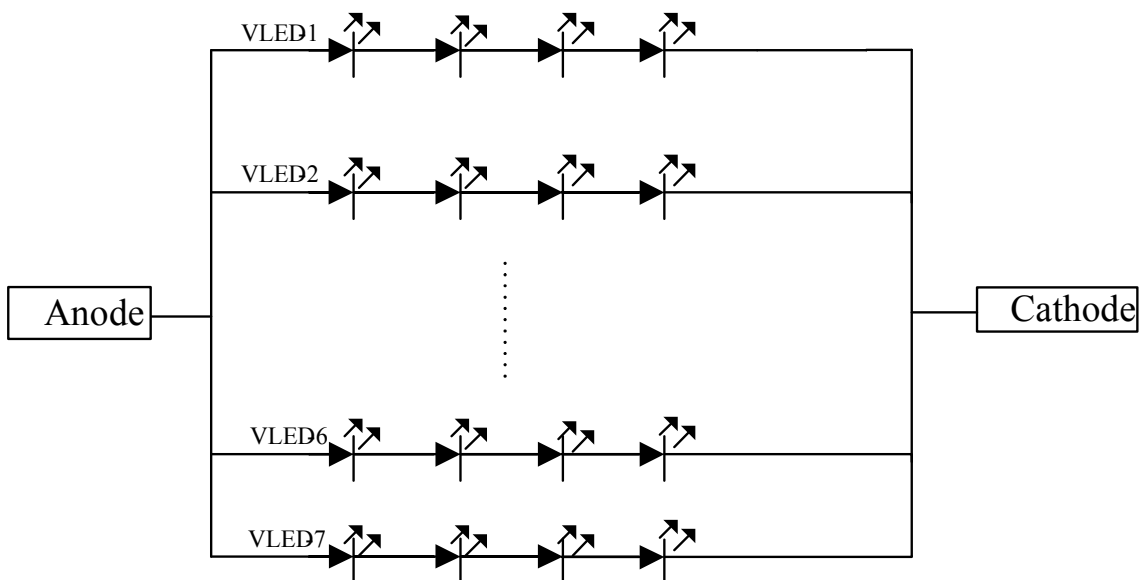

7-3) Power Consumption

Parameter	Symbol	Condition	Typ.	Max.	Unit	Remark
LCD Panel Power Consumption		-	627	684	mW	Note 7-6
Backlight Power Consumption		-	-	11.76	W	
Total Power Consumption		-	-	12.45	W	

Note 7-6: The power consumption for back light is not included.

7-4) Input / Output signal timing chart  
 (A) Vertical Timing

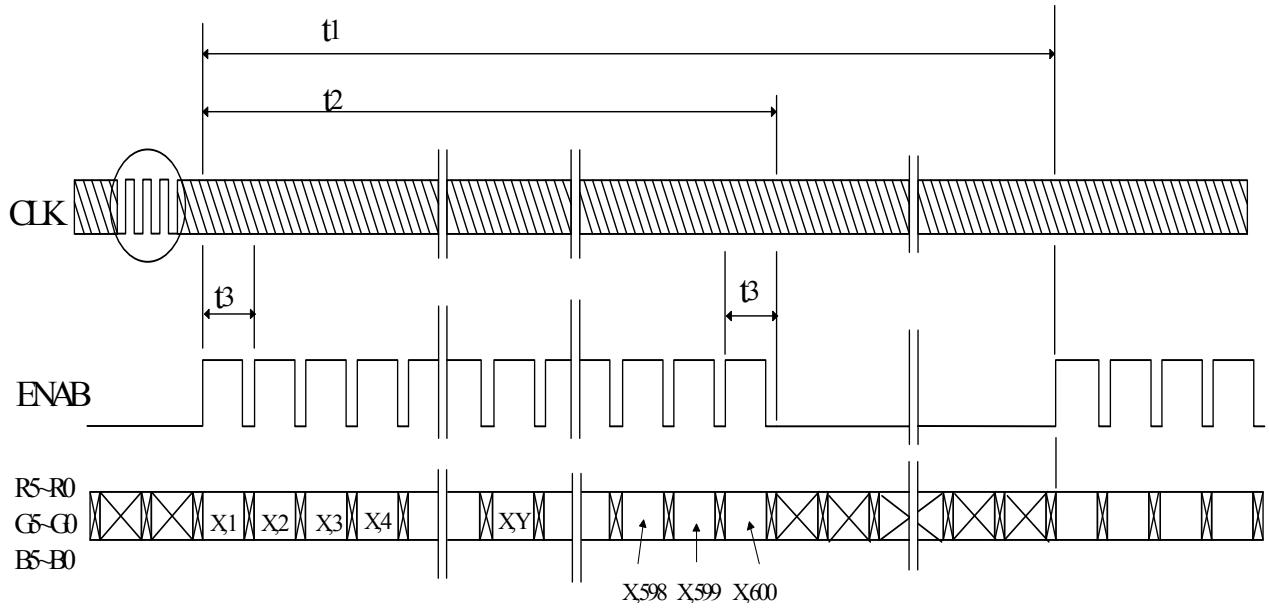

(B) Horizontal Timing

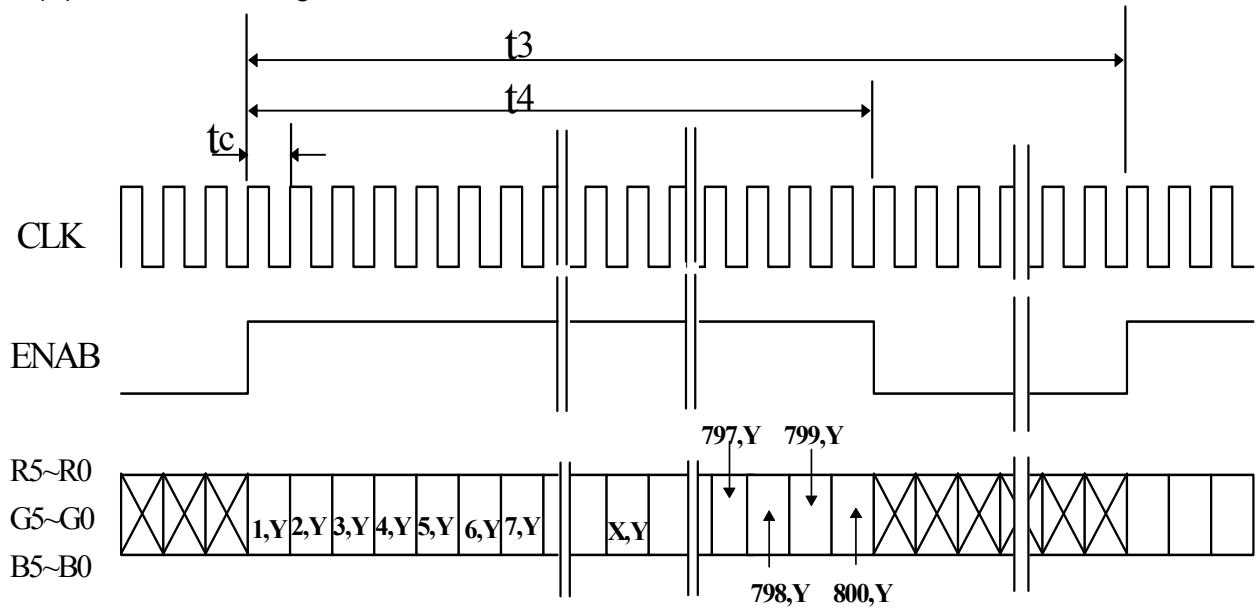

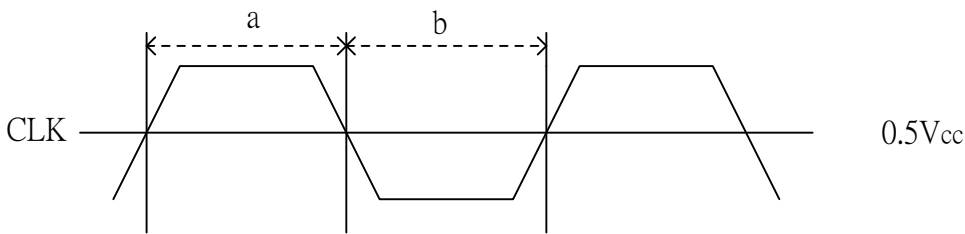
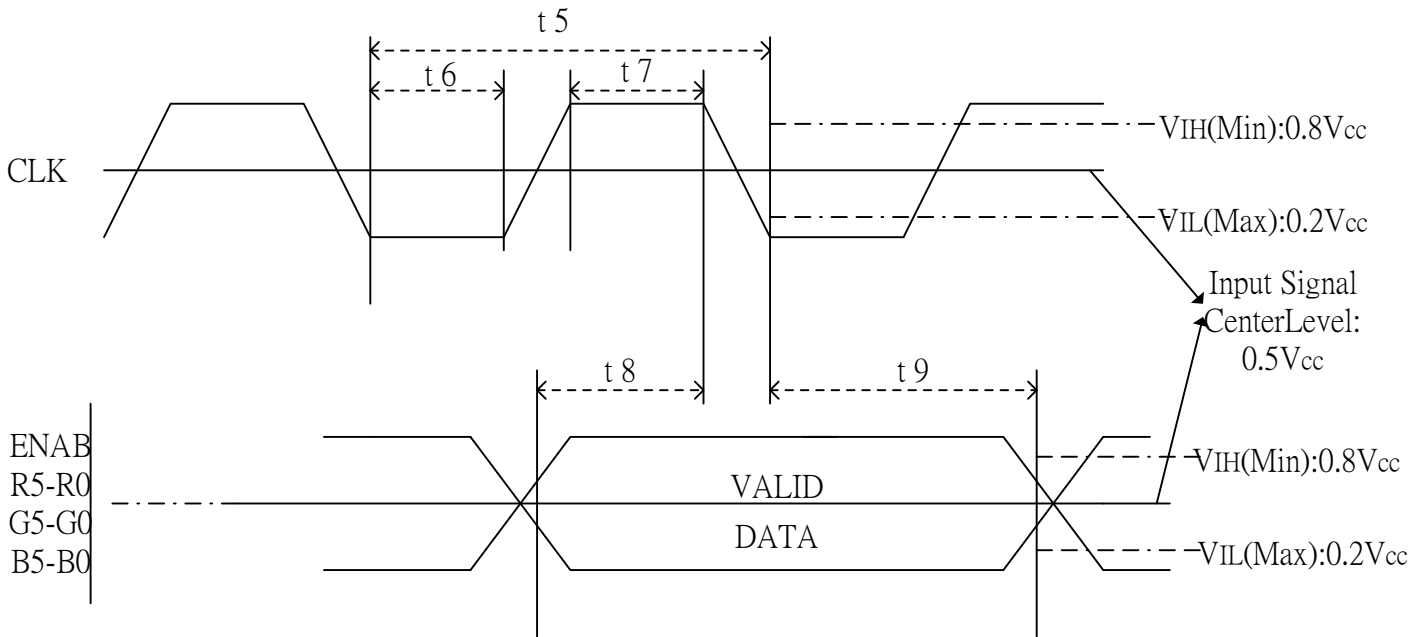

Duty ( a , b ) : 50 ± 10%

**C) Timing Specifications**

Item	symbol	Min.	Typ.	Max.	Unit	Remark
Frame Cycling	t1	604 X t3	628 X t3	800 X t3	-	
		-	16.58	-	ms	
Vertical Display Period	t2	600 X t3	600 X t3	600 X t3		
Horizontal Scanning Time	t3	920X t5	1056 X t5	1064 X t5		
		-	26.4	-	us	
Horizontal Display Period	t4	800 X t5	800 X t5	800 X t5		
Clock Cycle	t5	-	25.0	-	ns	
Clock High Level Time	t6	9.0	-	-	ns	
Clock Low Level Time	t7	9.0	-	-	ns	
Hold time	t8	4.0	-	-	ns	
Setup time	t9	5.0	-	-	ns	

7-5) Display Color and Gray Scale Reference

Color		Input Color Data																	
		Red						Green						Blue					
		R5	R4	R3	R2	R1	R0	G5	G4	G3	G2	G1	G0	B5	B4	B3	B2	B1	B0
Basic Colors	Black	0	0	0	0	0	0	0	0	0	0	0	0	0	0	0	0	0	0
	Red (63)	1	1	1	1	1	1	0	0	0	0	0	0	0	0	0	0	0	0
	Green (63)	0	0	0	0	0	0	1	1	1	1	1	1	0	0	0	0	0	0
	Blue (63)	0	0	0	0	0	0	0	0	0	0	0	0	1	1	1	1	1	1
	Cyan	0	0	0	0	0	0	1	1	1	1	1	1	1	1	1	1	1	1
	Magenta	1	1	1	1	1	1	0	0	0	0	0	0	1	1	1	1	1	1
	Yellow	1	1	1	1	1	1	1	1	1	1	1	1	0	0	0	0	0	0
	White	1	1	1	1	1	1	1	1	1	1	1	1	1	1	1	1	1	1
Red	Red (00)	0	0	0	0	0	0	0	0	0	0	0	0	0	0	0	0	0	0
	Red (01)	0	0	0	0	0	1	0	0	0	0	0	0	0	0	0	0	0	0
	Red (02)	0	0	0	0	1	0	0	0	0	0	0	0	0	0	0	0	0	0
	Darker																		
	↓	↓	↓	↓	↓	↓	↓	↓	↓	↓	↓	↓	↓	↓	↓	↓	↓	↓	↓
	Brighter																		
	Red (61)	1	1	1	1	0	1	0	0	0	0	0	0	0	0	0	0	0	0
	Red (62)	1	1	1	1	1	0	0	0	0	0	0	0	0	0	0	0	0	0
Red (63)	1	1	1	1	1	1	0	0	0	0	0	0	0	0	0	0	0	0	
Green	Green (00)	0	0	0	0	0	0	0	0	0	0	0	0	0	0	0	0	0	0
	Green (01)	0	0	0	0	0	0	0	0	0	0	0	1	0	0	0	0	0	0
	Green (02)	0	0	0	0	0	0	0	0	0	0	1	0	0	0	0	0	0	0
	Darker																		
	↓	↓	↓	↓	↓	↓	↓	↓	↓	↓	↓	↓	↓	↓	↓	↓	↓	↓	↓
	Brighter																		
	Green (61)	0	0	0	0	0	0	1	1	1	1	0	1	0	0	0	0	0	0
	Green (62)	0	0	0	0	0	0	1	1	1	1	1	0	0	0	0	0	0	0
Green (63)	0	0	0	0	0	0	1	1	1	1	1	1	0	0	0	0	0	0	
Blue	Blue (00)	0	0	0	0	0	0	0	0	0	0	0	0	0	0	0	0	0	0
	Blue (01)	0	0	0	0	0	0	0	0	0	0	0	0	0	0	0	0	0	1
	Blue (02)	0	0	0	0	0	0	0	0	0	0	0	0	0	0	0	0	1	0
	Darker																		
	↓	↓	↓	↓	↓	↓	↓	↓	↓	↓	↓	↓	↓	↓	↓	↓	↓	↓	↓
	Brighter																		
	Blue (61)	0	0	0	0	0	0	0	0	0	0	0	0	1	1	1	1	0	1
	Blue (62)	0	0	0	0	0	0	0	0	0	0	0	0	1	1	1	1	1	0
Blue (63)	0	0	0	0	0	0	0	0	0	0	0	0	1	1	1	1	1	1	

7-6) Pixel Arrangement

The LCD module pixel arrangement is the stripe.

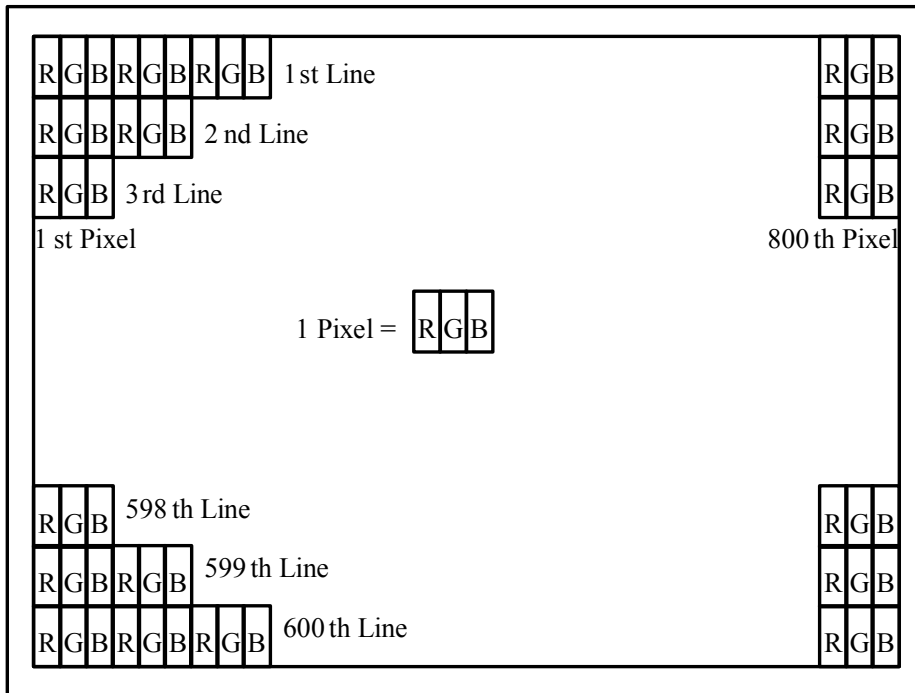

8 .Power On Sequence

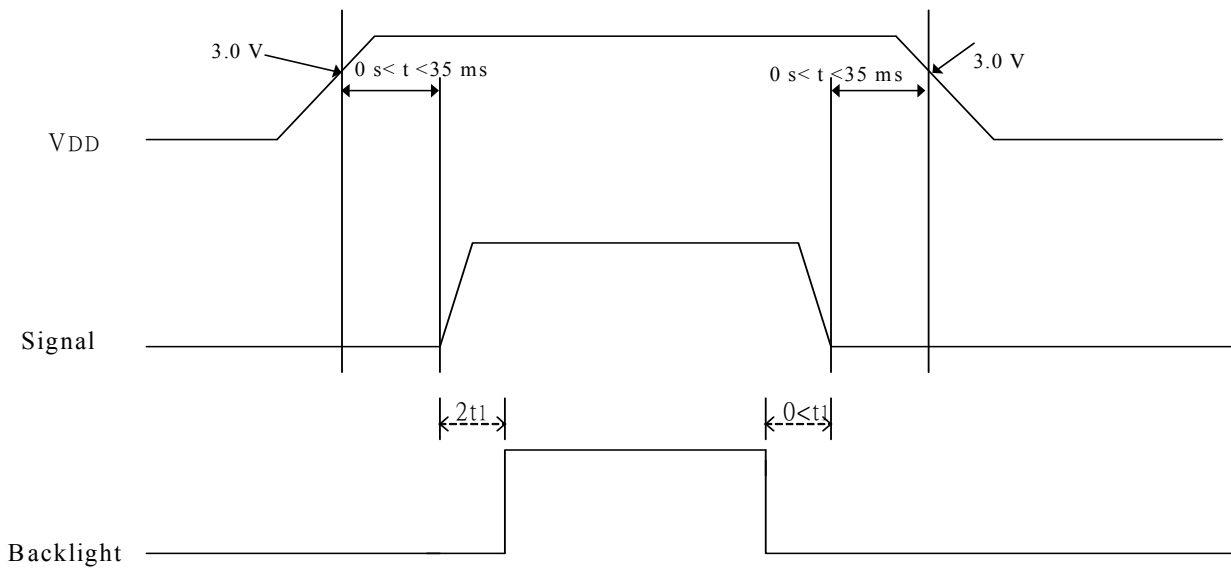

1. The supply voltage for input signals should be same as  $V_{DD}$ .
2. When the power is off , please keep whole signals (Hsync,Vsync,DENB,CLK, Data) low level or high impedance.

9.) Optical Characteristics

9-1) Specification:

Ta = +25°C

Parameter		Symbol	Condition	MIN.	TYP.	MAX.	Unit	Remarks
Viewing Angle	Horizontal	$\theta$ 21.22	CR $\geq$ 10	$\pm$ 70	$\pm$ 75	-	deg	Note 9-1
	Vertical	$\theta$ (to 12 o'clock)		55	60	-	deg	
		$\theta$ (to 6 o'clock)		45	50	-	deg	
Contrast Ratio		CR	$\theta = 0^\circ$	500	600	-	-	Note 9-2
Brightness		L	$\theta = 0^\circ / \varphi = 0^\circ$	1000	1200	-	cd/m <sup>2</sup>	Note 9-3
Response time	Rise	Tr	$\theta = 0^\circ / \varphi = 0^\circ$	-	15	50	ms	Note 9-4
	Fall	Tf		-	25	50	ms	
Luminance Uniformity		U	-	75	80	-	%	Note 9-5
White Chromaticity		x	$\theta = 0^\circ / \varphi = 0^\circ$	0.28	0.32	0.36	-	
		y		0.30	0.34	0.38	-	
Cross Talk Ratio		CTK	$\theta = 0^\circ / \varphi = 0^\circ$	-	-	3.5	%	Note 9-6
LED Life Time		-	+25°C	20000	30000	-	hrs	Note 9-7

All the optical measurement shall be executed 30 minutes after backlight being turn-on. The optical characteristics shall be measured in dark room (ambient illumination on panel surface less than 1 Lux). The measuring configuration shows as following figure.

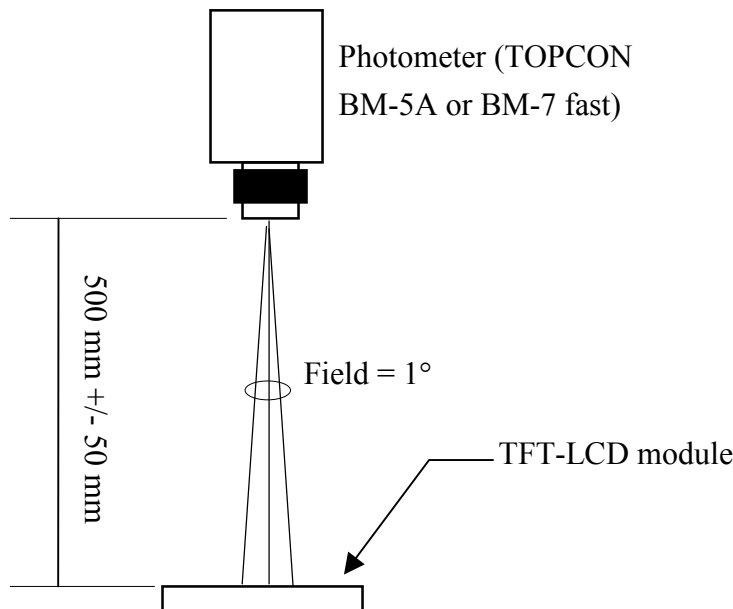

Optical characteristics measuring configuration

Note 9-1 : The definitions of viewing angles are as follows.

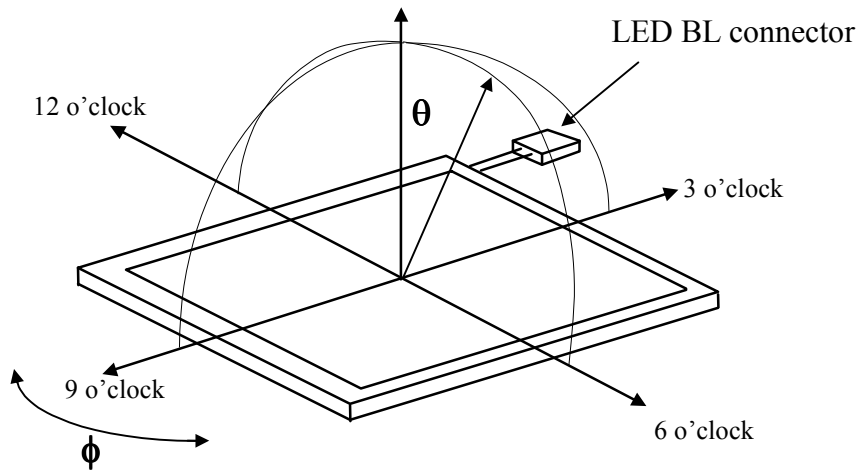

Note 9-2 : The definition of contrast ratio  $CR = \frac{\text{Luminance when Testing point is White}}{\text{Luminance when Testing point is Black}}$

Note 9-3 : Topcon BM-5A or BM-7 fast luminance meter 1° field of view is used in the testing .

Note 9-4: Definition of Response Time  $T_r$  and  $T_f$ :

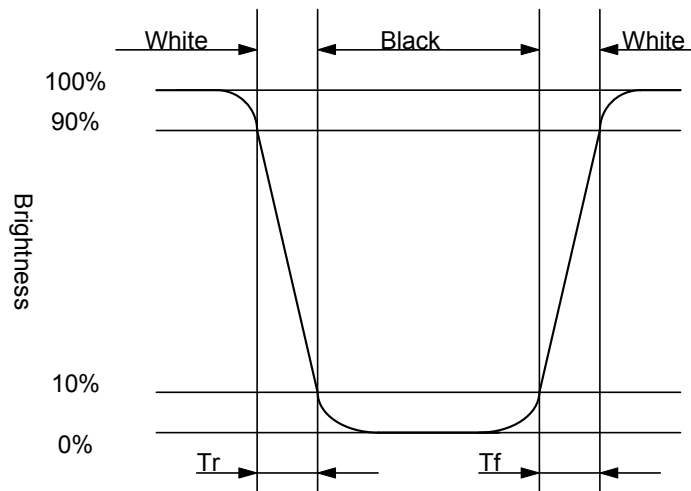

Note 9-5: The uniformity of LCD is defined as

$$U = \frac{\text{The Minimum Brightness of the 9 testing Points}}{\text{The Maximum Brightness of the 9 testing Points}}$$

Luminance meter : BM-5A or BM-7 fast(TOPCON)

Measurement distance : 500 mm +/- 50 mm

Ambient illumination : < 1 Lux

Measuring direction : Perpendicular to the surface of module

The test pattern is white.

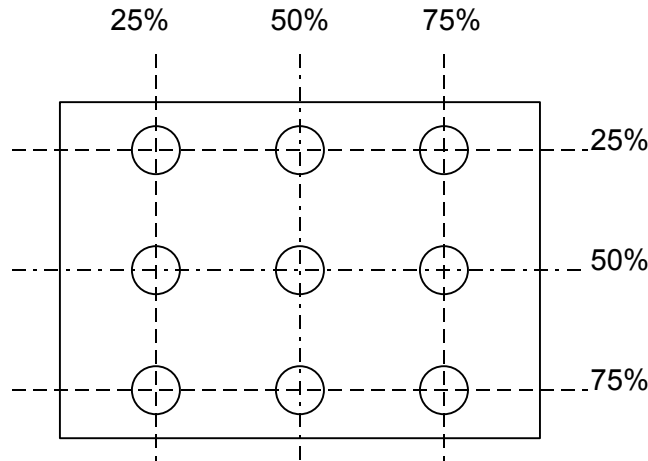

Note 9-6: Cross Talk (CTK) =  $\frac{|YA-YB|}{YA} \times 100\%$

YA: Brightness of Pattern A

YB: Brightness of Pattern B

Luminance meter : BM 5A or BM-7 fast (TOPCON)

Measurement distance : 500 mm +/- 50 mm

Ambient illumination : < 1 Lux

Measuring direction : Perpendicular to the surface of module

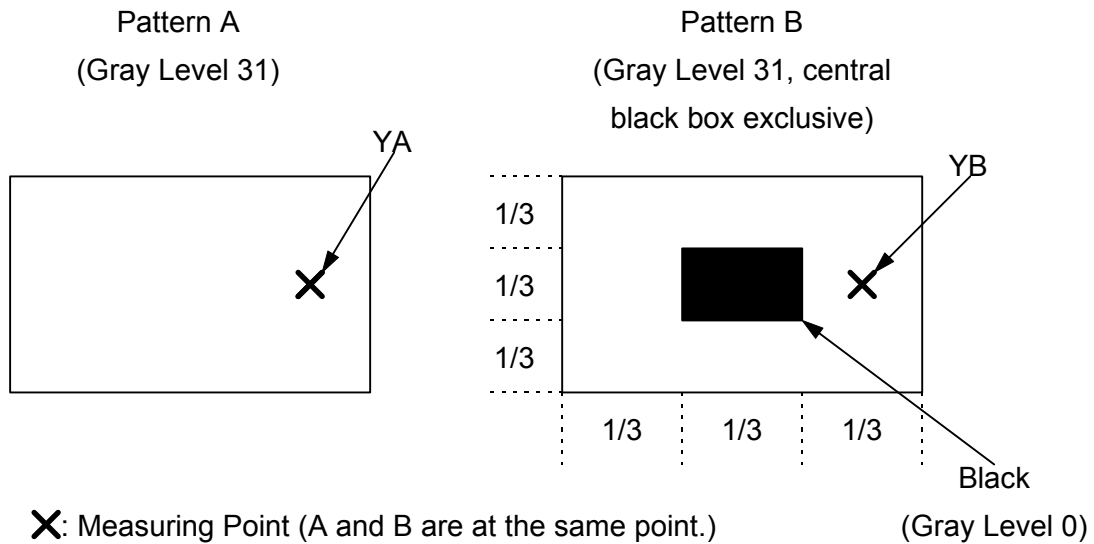

Note 9-7: The “LED Life time “ is defined as the module brightness decrease to 50% original Brightness that the ambient temperature is 25°C and I<sub>LED</sub> =840mA.

10. Handling Cautions

10-1) Mounting of module

- a) Please power off the module when you connect the input/output connector.
- b) Polarizer which is made of soft material and susceptible to flaw must be handled carefully.
- c) Protective film (Laminator) is applied on surface to protect it against scratches and dirt.
- d) Please following the tear off direction as figure 10-1 to remove the protective film as slowly as possible, so that electrostatic charge can be minimized.

10-2) Precautions in mounting

- a) When metal part of the TFT-LCD module (shielding lid and rear case) is soiled, wipe it with soft dry cloth.
- b) Wipe off water drops or finger grease immediately. Long contact with water may cause discoloration or spots.
- c) TFT-LCD module uses glass which breaks or cracks easily if dropped or bumped on hard surface. Please handle with care.
- d) Since CMOS LSI is used in the module. So take care of static electricity and earth yourself when handling.

10-3) Adjusting module

- a) Adjusting volumes on the rear face of the module have been set optimally before shipment.
- b) Therefore, do not change any adjusted values. If adjusted values are changed, the specifications described may not be satisfied.

10-4) Polarizer mark

The polarizer mark is to describe the direction of wide view angle film how to mach up with the rubbing direction.

10-5) Others

- a) Do not expose the module to direct sunlight or intensive ultraviolet rays for many hours.
- b) Store the module at a room temperature place.
- c) The voltage of beginning electric discharge may over the normal voltage because of leakage current from approach conductor by to draw lump read lead line around.
- d) If LCD panel breaks, it is possibly that the liquid crystal escapes from the panel. Avoid putting it into eyes or mouth. When liquid crystal sticks on hands, clothes or feet. Wash it out immediately with soap.
- e) Observe all other precautionary requirements in handling general electronic components.
- f) Please adjust the voltage of common electrode as material of attachment by 1 module.

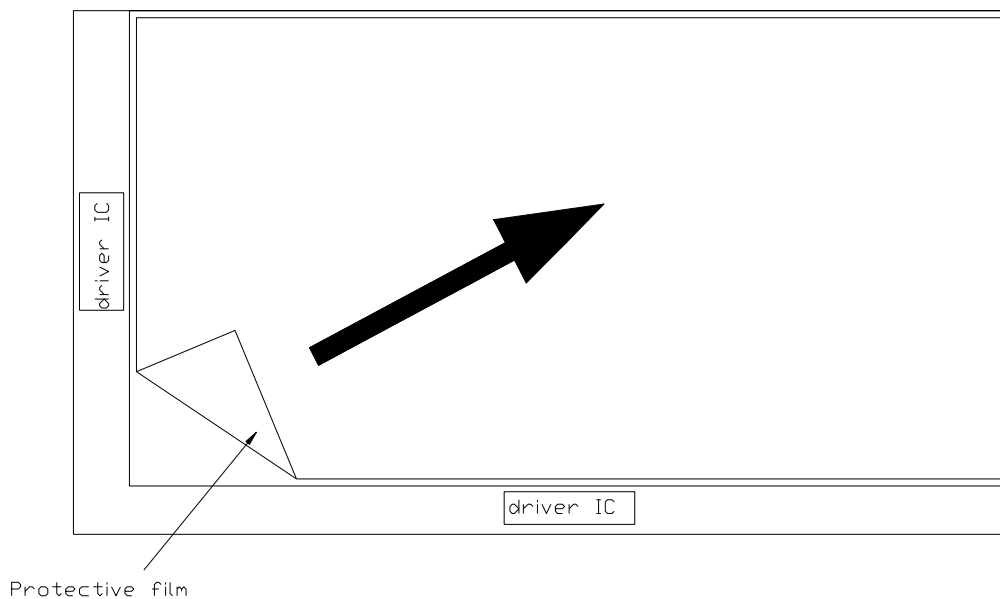

Figure 10-1 the way to peel off protective film

11. Reliability Test

No	Test Item	Test Condition	Remark
1	High Temperature Storage Test	Ta = +70°C, 240 hrs	
2	Low Temperature Storage Test	Ta = -30°C, 240 hrs	
3	High Temperature Operation Test	Ta = +70°C, 240 hrs	
4	Low Temperature Operation Test	Ta = -20°C, 240 hrs	
5	High Temperature & High Humidity Operation Test	Ta = +60°C, 90%RH, 240 hrs (No Condensation)	
6	Thermal Cycling Test (non-operating)	0°C ↔ +60°C, 100 Cycles 1Hr 1Hr	
7	Vibration Test (non-operating)	Frequency : 10 ~ 57 Hz, Amplitude : 0.15 mm, 58~500Hz, 1G Sweep time: 11 min Test Period: 3 hrs (1 hr for each direction of X, Y, Z)	
8	Shock Test (non-operating)	80G, 6ms, X,Y, Z 1 times for each direction	
9	Electron Static Discharge	C=150pF,R=330Ω Contact=±8KV Air=±15KV 10 times/terminal	

Ta: ambient temperature

Note: The protective film must be removed before temperature test.



[Criteria]

In the standard conditions, there is not display function NG issue occurred. (including : line defect ,no image). All the cosmetic specification is judged before the reliability stress.

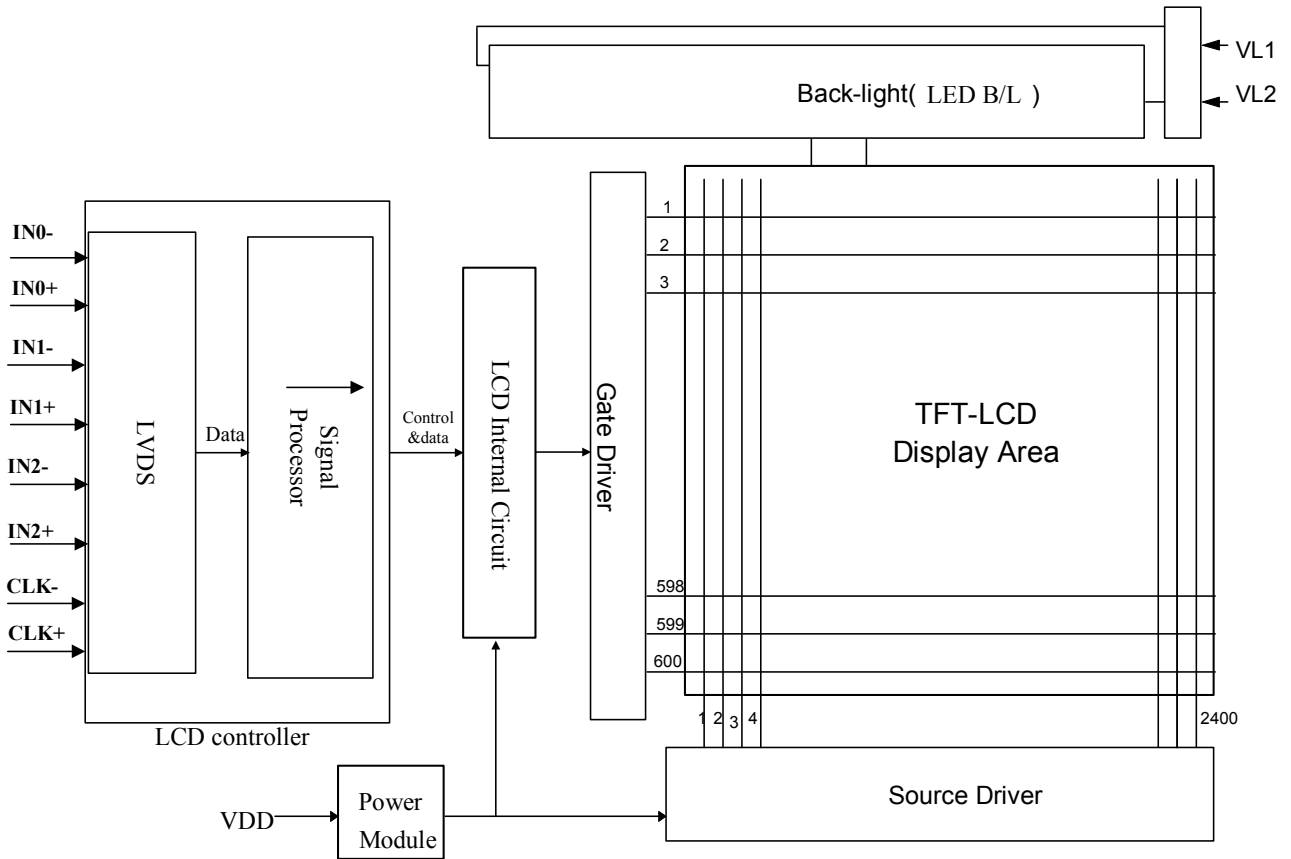
12. Block Diagram

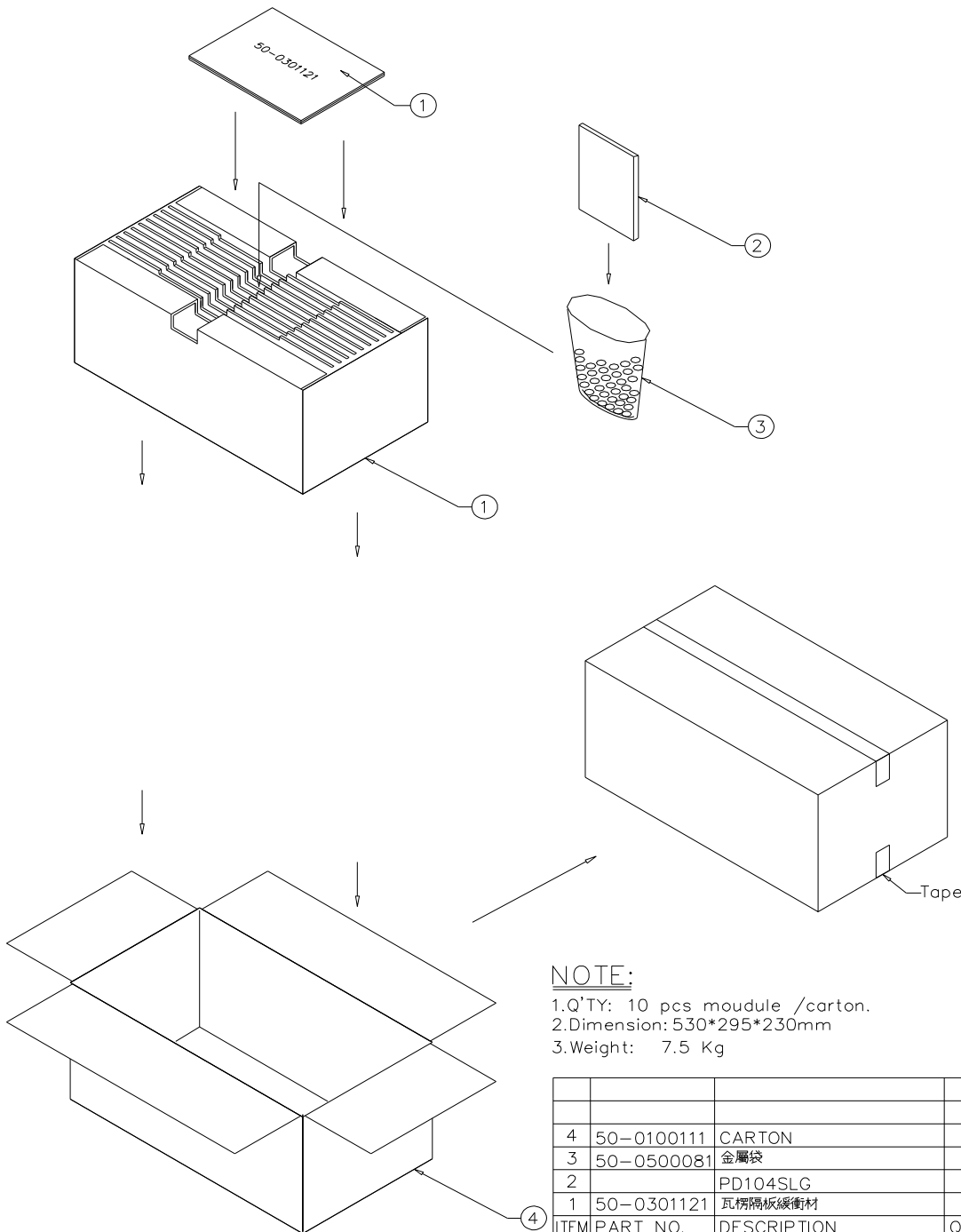

13.Packing

ZONE	REV.	DOCUMENT NO.	DESCRIPTION	DATE	REV. BY
					
<p><b>NOTE:</b></p> <p>1.Q'TY: 10 pcs moudule /carton.                  2.Dimension: 530*295*230mm                  3.Weight: 7.5 Kg</p>					
4		50-0100111	CARTON		1
3		50-0500081	金屬袋	10	抗靜電
2			PD104SLG	10	
1		50-0301121	瓦楞隔板緩衝材	1	上蓋+底座
ITEM	PART NO.	DESCRIPTION		QTY	REMARK
MTL.SPEC.		UNSPECIFIED TOL'S		REMARK	
		ANGLE			
		ROUGHNESS			
APPROVE	Frank	'08.07.14	SCALE	UNIT	SHEET
CHECK	Frank	'08.07.14			1 OF 1
DRAWN	Joseph	'08.07.14	MTL.NO.		DWG FILE:
				REV. 01	A4 SIZE
 元太科技工業股份有限公司 Prime View International Co., Ltd.					
DWG.TITLE PD104SLG Module Packing Draw					