

Version:0.1**TECHNICAL SPECIFICATION****Model NO. : PM061WX1**

The content of this information is subject to be changed without notice.
Please contact PVI or its agent for further information.

 Customer's Confirmation

Customer _____

Date _____

By _____

 PVI's Confirmation

Dep	FAE	Panel Design	Electronic Design	Mechanical Design	Product Verification	Prepared by
Sign						

Revision History

Rev.	Issued Date	Revised	Contents
0.1	Jan. 11, 2009	Preliminary	

TECHNICAL SPECIFICATION

CONTENTS

NO.	ITEM	PAGE
-	Cover	1
-	Revision History	2
-	Contents	3
1	Application	4
2	Features	4
3	Mechanical Specifications	4
4	Mechanical Drawing of TFT-LCD module	5
5	Input / Output Terminals	7
6	Absolute Maximum Ratings	11
7	Electrical Characteristics	11
8	Pixel Arrangement	13
9	Display Color and Gray Scale Reference	14
10	Block Diagram	15
11	Interface Timing	16
12	Power On Sequence	21
13	Optical Characteristics	21
14	Handling Cautions	25
15	Reliability Test	26
16	Packing Diagram	27

1. Application :

This data sheet applies to a color TFT LCD module, PM061WX1.

PM061WX1 module applies to OA product, portable DVD, car TV (must use Analog to Digital driving board), which requires high quality flat panel display. If you must use in severe reliability environment, please don't extend over PVI's reliability test conditions.

If you use PM061WX1, Prime View advises to use PVI's timing controller IC (PVI-2003A) on your system which will generate proper timing signals to control PM061WX1.

2. Features :

- . Wide VGA (800*480 pixels) resolution
- . Amorphous silicon TFT LCD panel with LED Back-light
- . Pixel in stripe configuration
- . Thin and light weight
- . Display Colors : 262,144 colors
- . TTL transmission interface
- . Wide view angle

3. Mechanical Specifications :

Parameter	Specifications	Unit
Screen Size	6.1 (diagonal)	inch
Display Format	800 × (R, G, B) × 480	dot
Display Colors	262,144	
Active Area	136.2 (H) × 72.0 (V)	mm
Pixel Pitch	0.17025 (H) × 0.150 (V)	mm
Pixel Configuration	Stripe	
Outline Dimension	149.0 (w) × 82.9 (H) × 5.9 (typ.) (D)	mm
Weight	(120)±10	g
Back-light	30-LED	
Surface treatment	Anti-glare	
Display mode	Normally White	
Gray scale inversion direction	6 o'clock [ref to Note 13-1]	

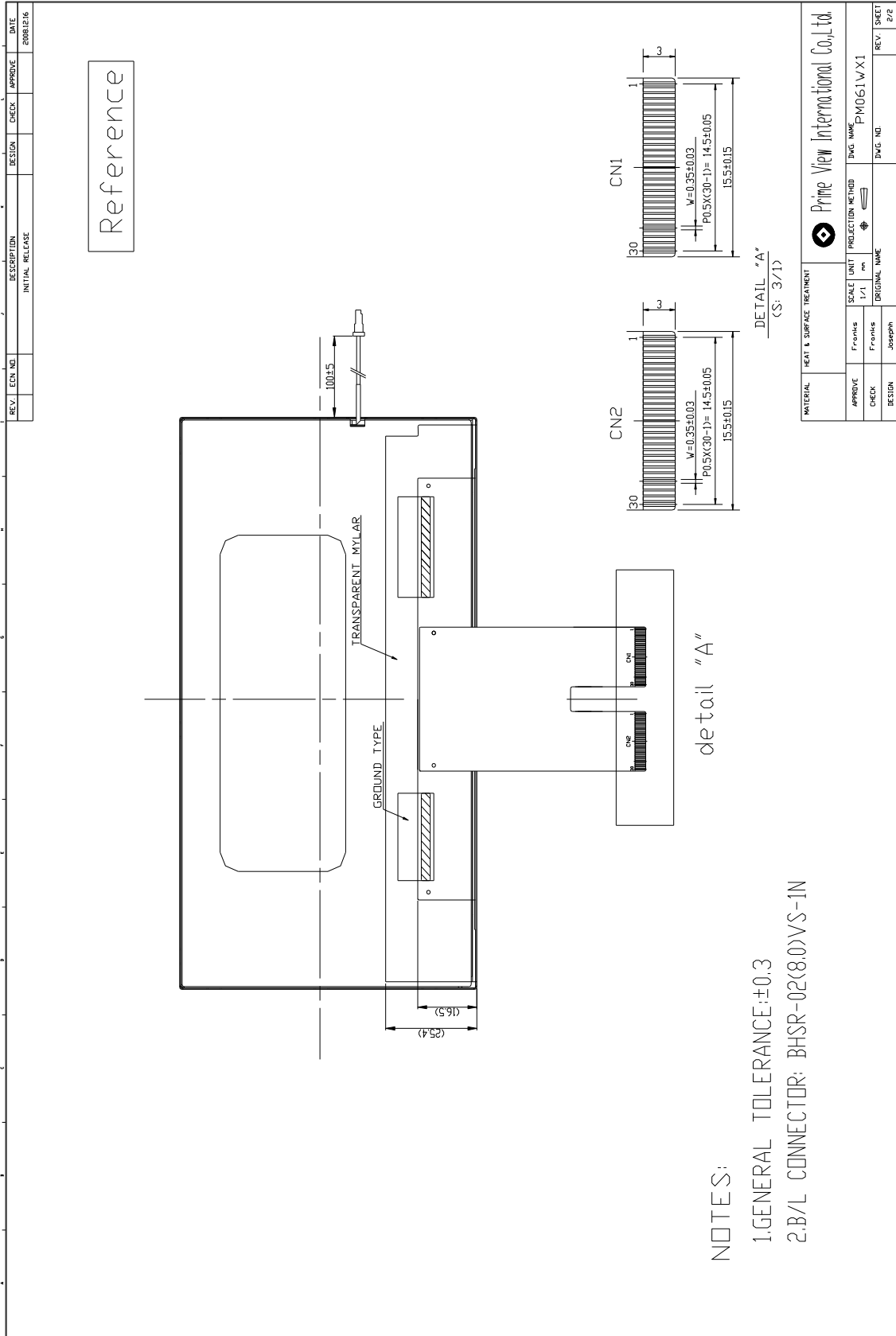

5. Input / Output Terminals :
5-1) TFT-LCD Panel Driving :

Connector type : IRISO 9637S-30Y905 30pin Pitch : 0.5mm

CN 1

Pin No.	Symbol	I/O	Function	Remark
1	DIO1	I/O	Horizontal Start Pulse Signal Input or Output	Note 5-6
2	VSS1	I	Ground	
3	VDD1	I	Power Supply	
4	CLK	I	Horizontal Shift Clock	Note 5-4
5	VSS1	I	Ground	
6	R/L	I	Right / Left selection	Note 5-6
7	R0	I	Red Data (LSB)	
8	R1	I	Red Data	
9	R2	I	Red Data	
10	R3	I	Red Data	
11	R4	I	Red Data	
12	R5	I	Red Data (MSB)	
13	VSS1	I	Ground	
14	G0	I	Green Data (LSB)	
15	G1	I	Green Data	
16	G2	I	Green Data	
17	G3	I	Green Data	
18	G4	I	Green Data	
19	G5	I	Green Data (MSB)	
20	VSS1	I	Ground	
21	B0	I	Blue Data (LSB)	
22	B1	I	Blue Data	
23	B2	I	Blue Data	
24	B3	I	Blue Data	
25	B4	I	Blue Data	
26	B5	I	Blue Data (MSB)	
27	LD	I	Load output signal	Note 5-7
28	REV	I	Data invert control	Note 5-8
29	POL	I	Polarity selection	Note 5-9
30	DIO2	I/O	Horizontal Start Pulse Signal Input or Output	Note 5-6

CN 2

Pin No.	Symbol	I/O	Function	Remark
1	VSS2	I	Ground	
2	V1	I	Gamma Voltage 1	Note 5-10
3	V2	I	Gamma Voltage 2	
4	V3	I	Gamma Voltage 3	
5	V4	I	Gamma Voltage 4	
6	V5	I	Gamma Voltage 5	
7	V6	I	Gamma Voltage 6	
8	V7	I	Gamma Voltage 7	
9	VSS2	I	Ground	
10	V8	I	Gamma Voltage 8	Note 5-10
11	V9	I	Gamma Voltage 9	
12	V10	I	Gamma Voltage 10	
13	V11	I	Gamma Voltage 11	
14	V12	I	Gamma Voltage 12	
15	V13	I	Gamma Voltage 13	
16	V14	I	Gamma Voltage 14	
17	VSS2	I	Ground	
18	VDD2	I	Voltage for analog circuit	
19	VCOM	I	Common Voltage	
20	XON	I	NC	
21	OE	I	Output Enable	Note 5-5
22	U/D	I	Up / Down Selection	Note 5-3
23	CKV	I	Vertical Shift Clock	Note 5-7
24	STVU	I/O	Vertical Shift Pulse Signal Input or Output	Note 5-3
25	STVD	I/O	Vertical Shift Pulse Signal Input or Output	Note 5-3
26	VGG	I	Gate On Voltage	Note 5-2
27	GND	I	Ground	
28	VCC	I	Voltage for logic circuit	
29	GND	I	Ground	
30	VEE	I	Gate Off Voltage	Note 5-1

Note 5-1 : Gate off voltage, $V_{EE(TYP.)} = -8V$

Note 5-2 : Gate on voltage, $V_{GG(TYP.)} = +17V$

Note 5-3 : Select up or down shift

U/D	STVU	STVD	Shift
1	Hi-Z	Input	Down to Up
0	Input	Hi-Z	Up to Down

Note 5-4 : Gate driver shift clock

Note 5-5 : When OE is connected to high "1", the driver outputs are disabled (Gate output = V_{EE}).
Under this condition, the operation of registers will not be affected.

Note 5-6 : Select left or right shift

R/L	DIO1	DIO2	Shift
1	Input	Hi-Z	Left to right
0	Hi-Z	Input	Right to left

Note 5-7 : Latch the polarity of outputs and switch the new data to outputs. At the rising edge (LD), latch the "POL" signal to control the polarity of the outputs.

Note 5-8 : Control whether the Data R0~G5 are inverted or not. (PVI suggests connecting to GND)
When "REV=1", these data will be inverted.
EX: "00"→"3F", "07"→"38", "15"→"2A"

Note 5-9 : Polarity selector for dot-inversion control. Available at the rising edge of LD.
When POL=1: Even outputs range from V1~V7, and Odd outputs range from V8~V14;
When POL=0: Even outputs range from V8~V14, and Odd outputs range from V1~V7.

Note 5-10 : Typical Application Circuit (When V_{DD2} (Typ.) = +9.5V)

TBD

5-2) Backlight driving :

Connector type : JST BHSR-02VS-1

Pin No	Symbol	Description	Remark
1	+	Input terminal (Anode)	Wire color : Red
2	-	Input terminal (Cathode)	Wire Color : Black

6. Absolute Maximum Ratings :

VSS1=VSS2=GND=0V, Ta=25°C

Parameters	Symbol	MIN.	MAX.	Unit	Remark
Supply Voltage	V _{DD1}	-0.3	5.0	V	
	V _{CC}			V	
	V _{DD2}	-0.5	12.0	V	
	V _{GG}	-0.3	40.0	V	
	V _{GG-V_{EE}}	-	40.0	V	
	V _{EE}	-20	0.3	V	
Operating Temperature	Top	-30	85	°C	
Storage Temperature	Tst	-40	95	°C	

7. Electrical Characteristics :

7-1) Recommended Operating Conditions :

VSS1=VSS2=GND=0V, Ta=25°C

Item	Symbol	Min.	Typ.	Max.	Unit	Remark
Supply Voltage for Source Driver	V _{DD1}	3.0	3.3	3.6	V	
	V _{DD2}	-	(9.5)	-	V	
Supply Voltage for Gate Driver	V _{GG}	-	(17)	-	V	
	V _{EE}	-	(-8)	-	V	
	V _{CC}	3.0	3.3	3.6	V	
Digital Input Voltage	V _{IH}	0.8V _{DD1}	-	V _{DD1}	V	
	V _{IL}	0	-	0.2V _{DD1}	V	
V _{com} Voltage	V _{com}	-	TBD	-	V	

7-2) Recommended driving condition for LED back light :

Ta = 25°C

Parameter	Symbol	Min	TYP	MAX	Unit	Remark
Supply voltage of LED backlight	V _{LED}	-	-	(11)	V	Note 7-1
Supply current of LED backlight	I _{LED}	-	15	-	mA	Note 7-2
Backlight Power Consumption	P _{LED}	-	-	1650	mW	Note 7-3

Note 7-1 : The I_{LED}=20 mA, Constant current.

Note 7-2 : The LED driving condition is defined for each LED module. (3 LED Serial)

$$\text{Input current} = 15\text{mA} * 10 = 150\text{mA}$$

Note 7-3 : $P_{LED} = V_{LED-1} * I_{LED-1} + V_{LED-2} * I_{LED-2} \dots\dots + V_{LED-9} * I_{LED-9} + V_{LED-10} * I_{LED-10}$

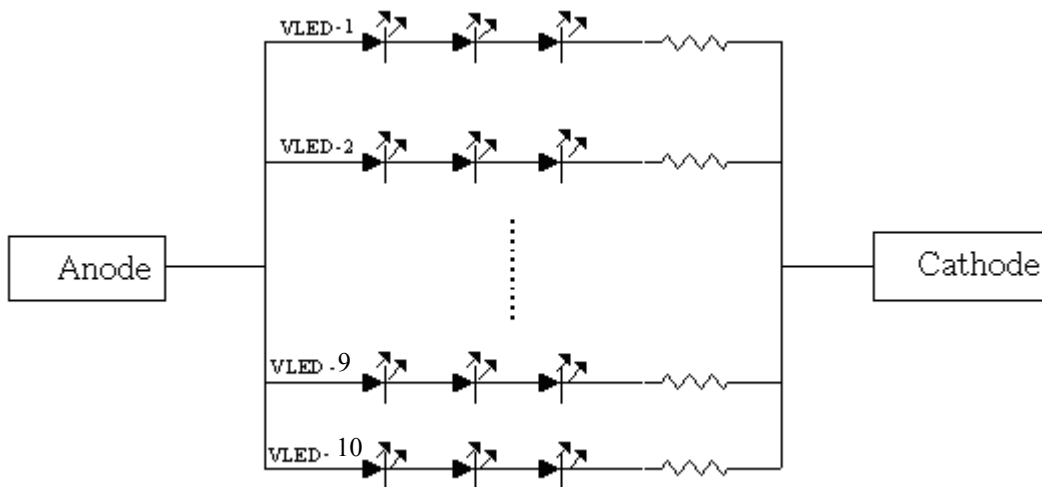

7-3) Power Consumption :

Parameter	Symbol	Condition	Typ.	Max.	Unit	Remark
Supply Current for Gate Driver (Hi level)	I _{GG}	V _{GG} = +17V	TBD	-	mA	
Supply Current for Gate Driver (Low level)	I _{EE}	V _{EE} = -8V	TBD	-	mA	
Supply Current for Source Driver (Digital)	I _{DD1}	V _{DD1} = +3.3	TBD	-	mA	
Supply Current for Source Driver (Analog)	I _{DD2}	V _{DD2} = +9.5	TBD	-	mA	
Supply Current for Gate Driver (Digital)	I _{CC}	V _{CC} = +3.3	TBD	-	mA	
LCD Panel Power Consumption			TBD	-	mW	Note 7-4
Total Power Consumption			-	TBD	mW	

Note 7-4 : The power consumption for back light is not included.

8. Pixel Arrangement :

The LCD module pixel arrangement is the stripe.

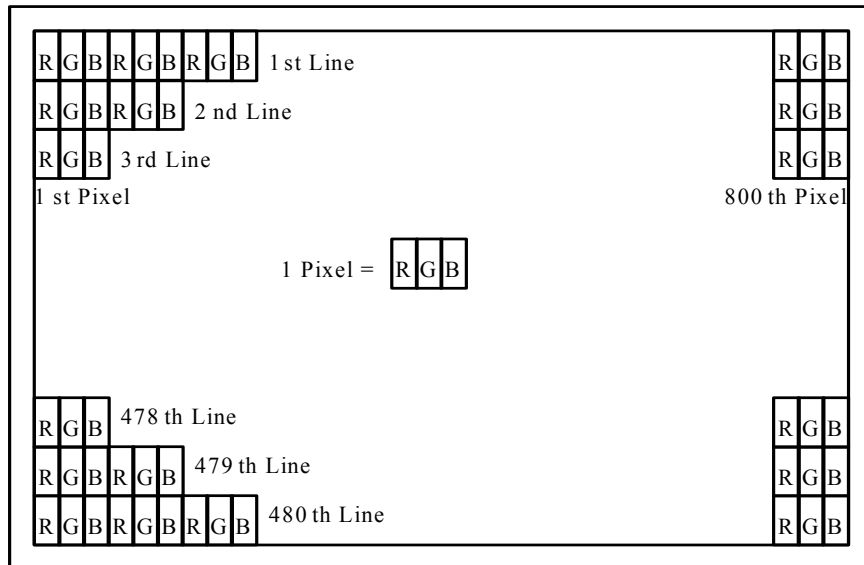

9. Display Color and Gray Scale Reference :

Color		Input Color Data																	
		Red					Green					Blue							
		R5	R4	R3	R2	R1	R0	G5	G4	G3	G2	G1	G0	B5	B4	B3	B2	B1	B0
Basic Colors	Black	0	0	0	0	0	0	0	0	0	0	0	0	0	0	0	0	0	0
	Red (63)	1	1	1	1	1	1	0	0	0	0	0	0	0	0	0	0	0	0
	Green (63)	0	0	0	0	0	0	1	1	1	1	1	1	0	0	0	0	0	0
	Blue (63)	0	0	0	0	0	0	0	0	0	0	0	0	1	1	1	1	1	1
	Cyan	0	0	0	0	0	0	1	1	1	1	1	1	1	1	1	1	1	1
	Magenta	1	1	1	1	1	1	0	0	0	0	0	0	1	1	1	1	1	1
	Yellow	1	1	1	1	1	1	1	1	1	1	1	1	0	0	0	0	0	0
	White	1	1	1	1	1	1	1	1	1	1	1	1	1	1	1	1	1	1
Red	Red (00)	0	0	0	0	0	0	0	0	0	0	0	0	0	0	0	0	0	0
	Red (01)	0	0	0	0	0	1	0	0	0	0	0	0	0	0	0	0	0	0
	Red (02)	0	0	0	0	1	0	0	0	0	0	0	0	0	0	0	0	0	0
	Darker																		
	↓	↓	↓	↓	↓	↓	↓	↓	↓	↓	↓	↓	↓	↓	↓	↓	↓	↓	↓
	Brighter																		
	Red (61)	1	1	1	1	0	1	0	0	0	0	0	0	0	0	0	0	0	0
	Red (62)	1	1	1	1	1	0	0	0	0	0	0	0	0	0	0	0	0	0
	Red (63)	1	1	1	1	1	1	0	0	0	0	0	0	0	0	0	0	0	0
Green	Green (00)	0	0	0	0	0	0	0	0	0	0	0	0	0	0	0	0	0	0
	Green (01)	0	0	0	0	0	0	0	0	0	0	0	1	0	0	0	0	0	0
	Green (02)	0	0	0	0	0	0	0	0	0	0	1	0	0	0	0	0	0	0
	Darker																		
	↓	↓	↓	↓	↓	↓	↓	↓	↓	↓	↓	↓	↓	↓	↓	↓	↓	↓	↓
	Brighter																		
	Green (61)	0	0	0	0	0	0	1	1	1	1	0	1	0	0	0	0	0	0
	Green (62)	0	0	0	0	0	0	1	1	1	1	1	0	0	0	0	0	0	0
	Green (63)	0	0	0	0	0	0	1	1	1	1	1	1	0	0	0	0	0	0
Blue	Blue (00)	0	0	0	0	0	0	0	0	0	0	0	0	0	0	0	0	0	0
	Blue (01)	0	0	0	0	0	0	0	0	0	0	0	0	0	0	0	0	0	1
	Blue (02)	0	0	0	0	0	0	0	0	0	0	0	0	0	0	0	0	1	0
	Darker																		
	↓	↓	↓	↓	↓	↓	↓	↓	↓	↓	↓	↓	↓	↓	↓	↓	↓	↓	↓
	Brighter																		
	Blue (61)	0	0	0	0	0	0	0	0	0	0	0	0	1	1	1	1	0	1
	Blue (62)	0	0	0	0	0	0	0	0	0	0	0	0	1	1	1	1	1	0
	Blue (63)	0	0	0	0	0	0	0	0	0	0	0	0	1	1	1	1	1	1

10. Block Diagram :
TFT-module Block Diagram :

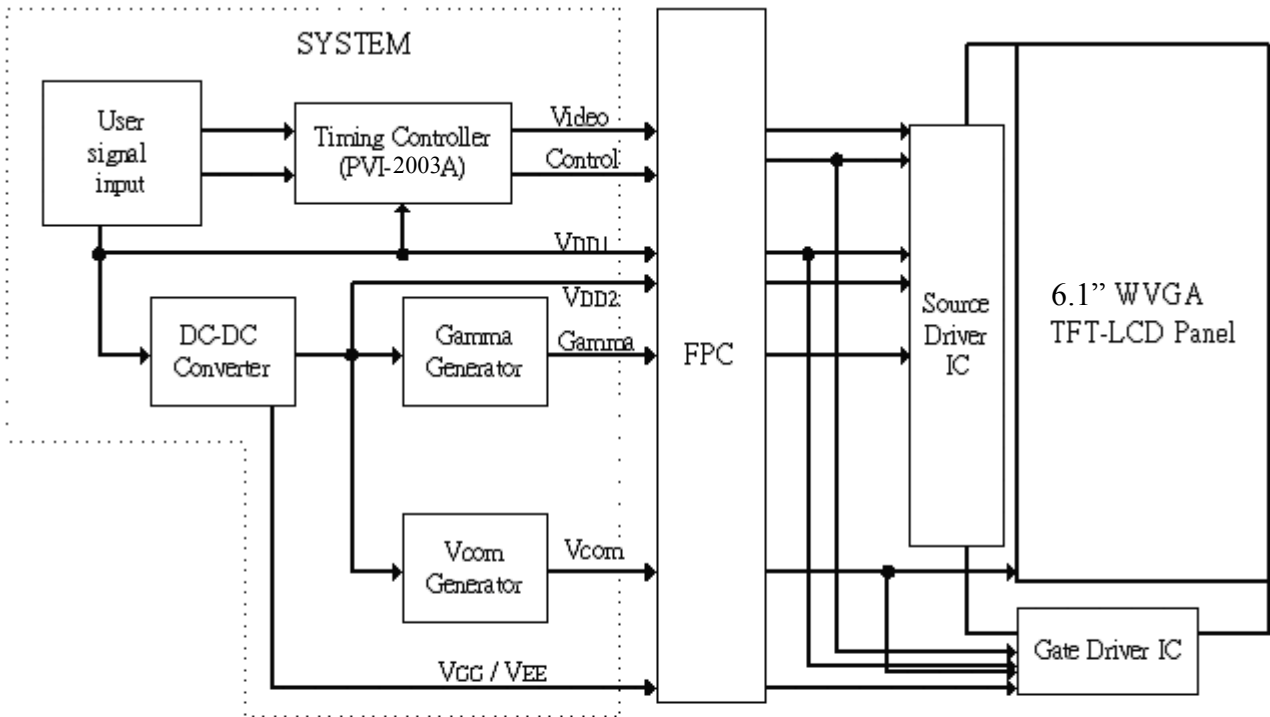

If you use PM061WX1 , you can apply PVI-2003 A (Timing controller) which will generate timing signals to support PM061WX1 .

11. Interface Timing

11.1) Timing Parameters

AC Electrical Characteristics ($V_{CC}=V_{DD1}= 3.3V$, $V_{DD2}=9.5V$, $GND=V_{SS1}=V_{SS2}=0V$, $T_a=25^{\circ}C$)

Parameter	Symbol	Min.	Typ.	Max.	Unit
CLK Frequency	F _{clk}	-	32	40	MHz
CLK Pulse Width	T _{cw}	25	-	-	ns
Data Set-up Time	T _{su}	4	-	-	ns
Data Hold Time	T _{hd}	2	-	-	ns
Propagation Delay of DIO2/1	T _{phl}	6	10	15	ns
Time That The Last Data to LD	T _{ld}	1	-	-	T _{cw}
Pulse width of LD	T _{wld}	2	-	-	T _{cw}
Time That LD to DIO1/2	T _{lds}	5	-	-	T _{cw}
POL Set-up Time	T _{psu}	6	-	-	ns
POL Hold Time	T _{phd}	6	-	-	ns
OE Pulse Width	T _{OE_V}	1	-	-	μs
CKV Pulse Width	T _{CKV}	500	-	-	ns
STV Set-up Time	T _{SUV}	400	-	-	ns
STV Hold Time	T _{HDV}	400	-	-	ns
Horizontal Display Period	T _{HDP}	-	800	-	T _{cw}
Horizontal Period Timing Range	T _{HP}	-	1056	-	T _{cw}
Horizontal Lines Per Field	T _V	484	508	620	T _{HP}
Vertical Display Timing Range	T _{DV}	-	480	-	T _{HP}

11.2) Timing Diagram :

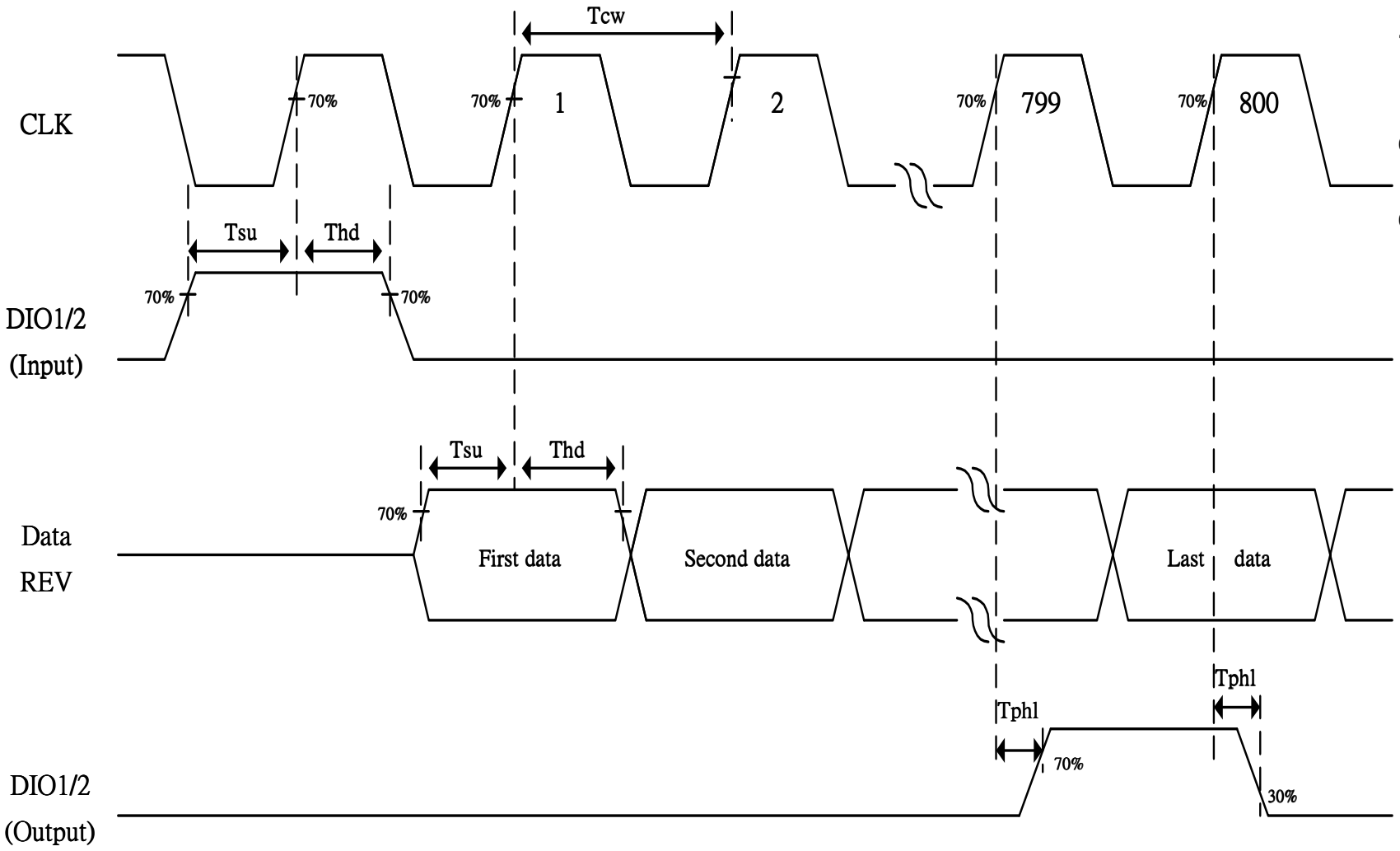

Fig. 11-1 Horizontal timing (1)

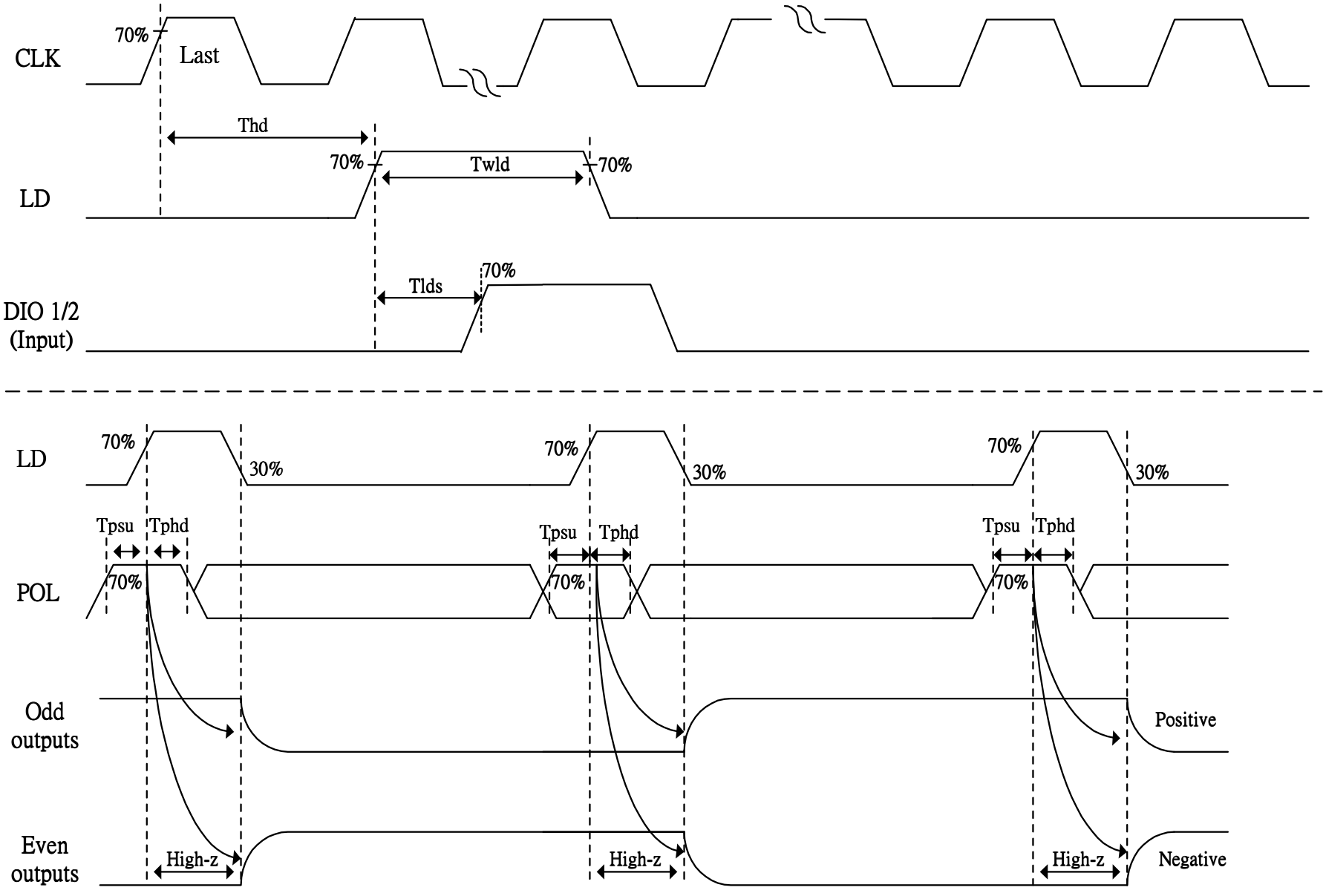

Fig. 11-2 Horizontal timing(2)

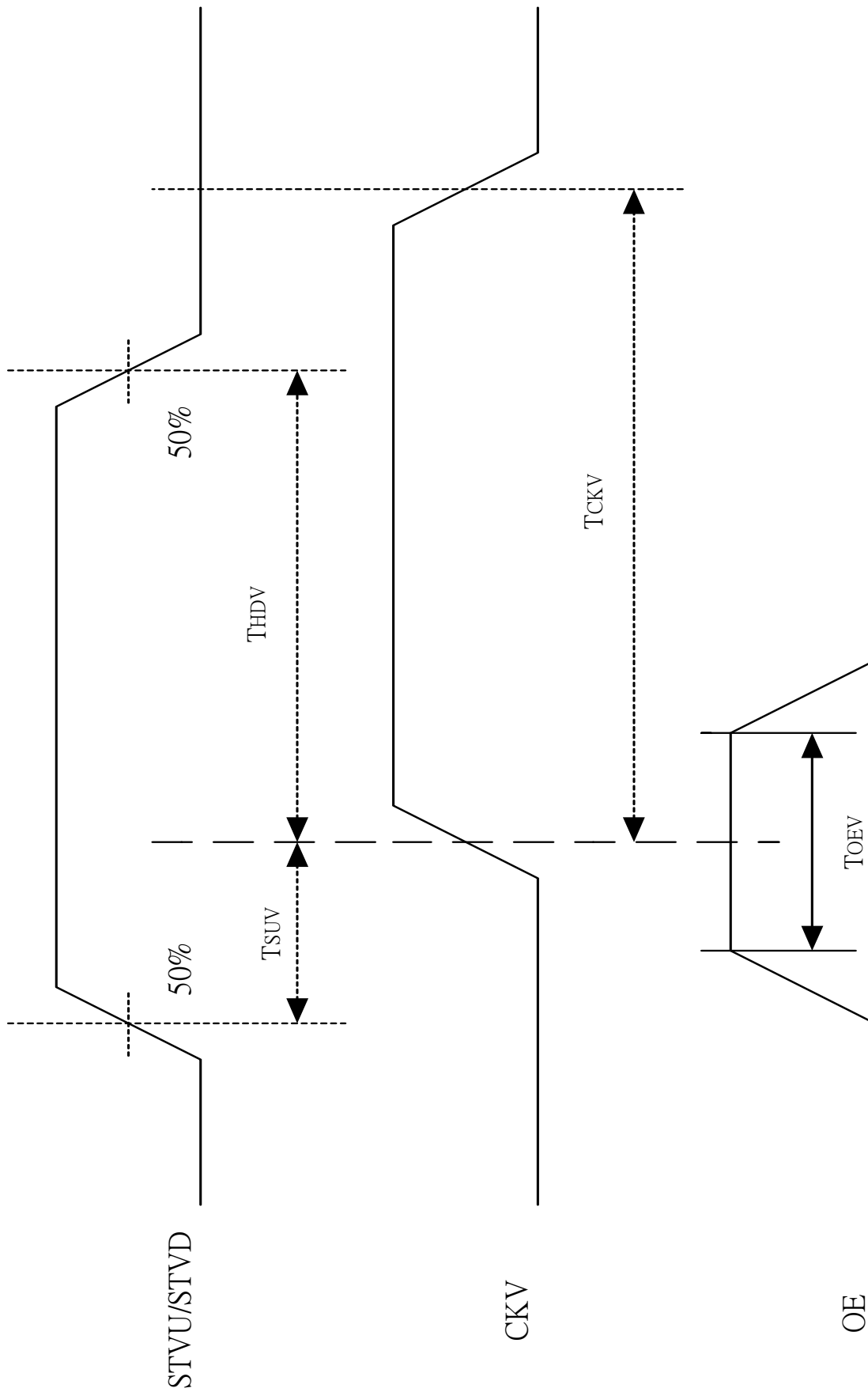

Fig. 11-3 Vertical shift clock timing

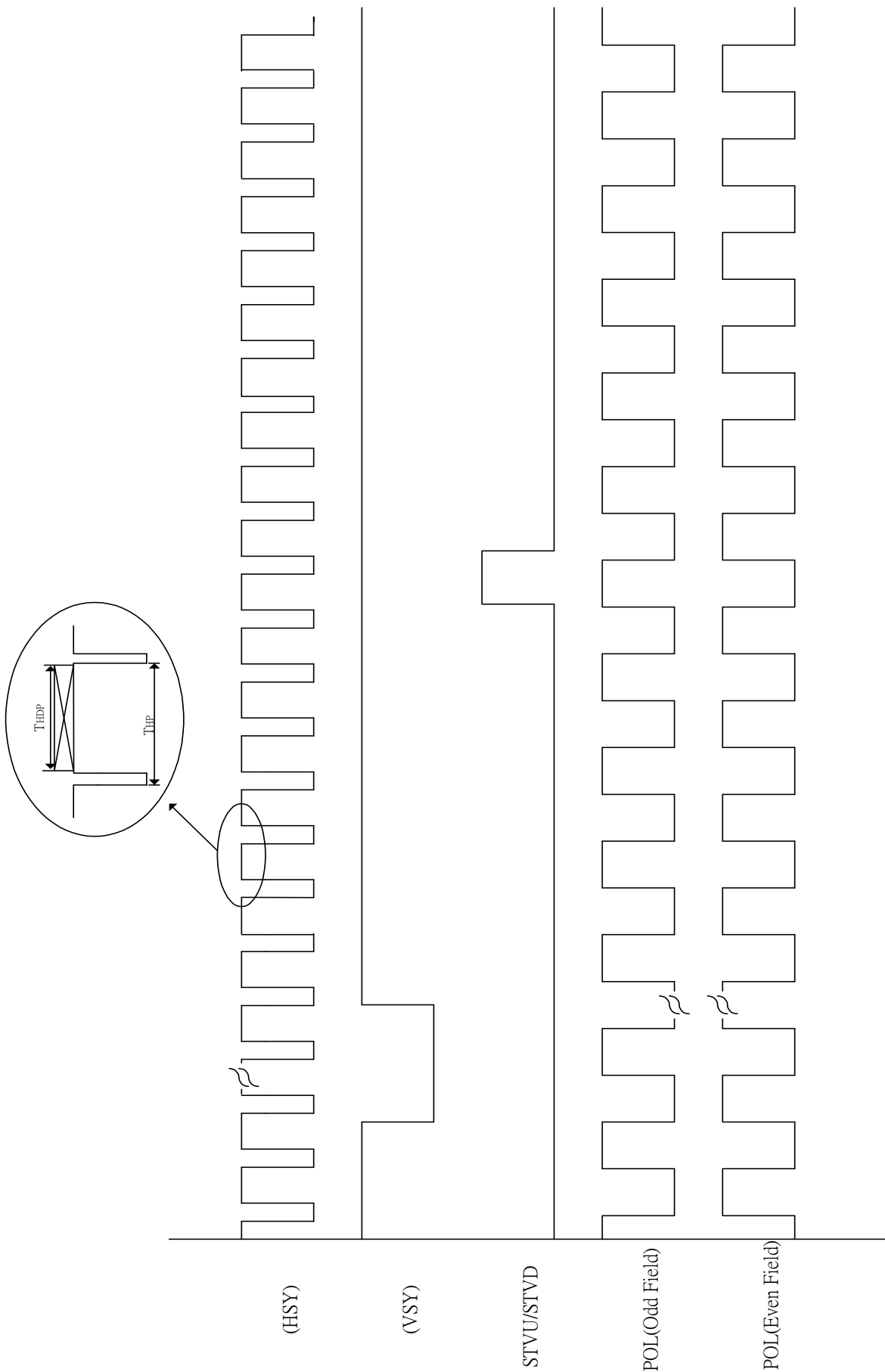
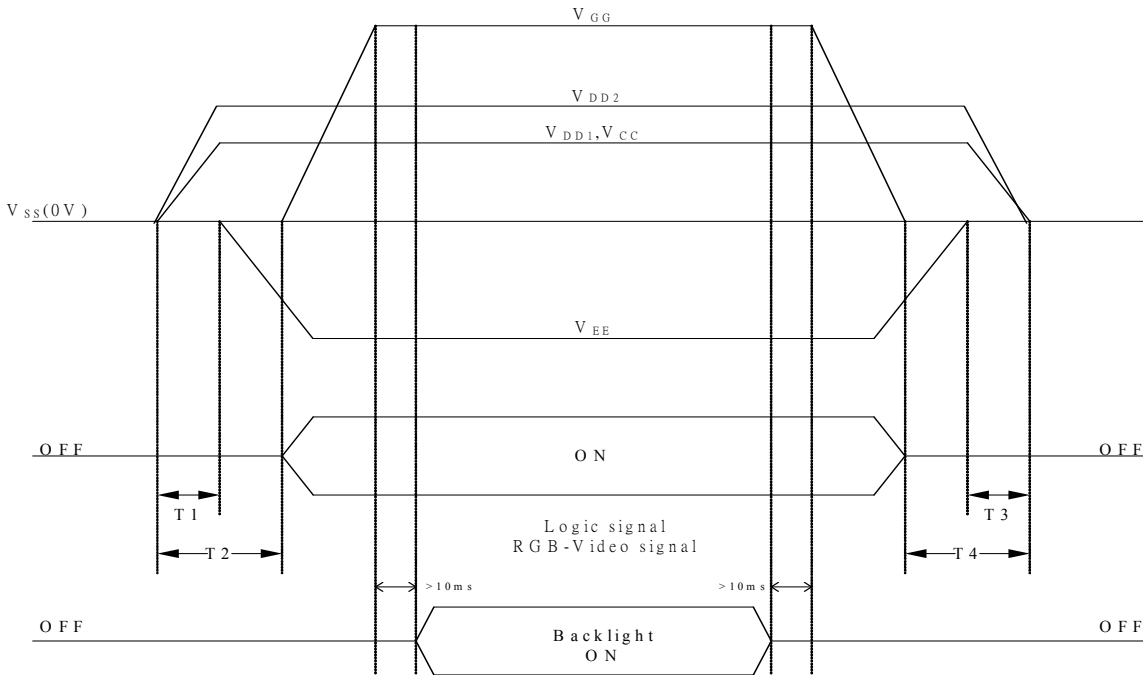

Fig. 11-4 Vertical timing

12. Power On Sequence :



1. $10\text{ms} \leq T_1 < T_2$

2. $0\text{ms} < T_3 \leq T_4 \leq 10\text{ms}$

13. Optical Characteristics :

13-1) Specification :

Ta=25°C

Parameter		Symbol	Condition	MIN.	TYP.	MAX.	Unit	Remarks
Viewing Angle	Horizontal	$\theta 21, \theta 22$	CR ≥ 10	70	75	-	deg	Note 13-1
	Vertical	$\theta 12$		45	50	-	deg	
		$\theta 11$		65	70	-	deg	
Contrast Ratio		CR	At optimized Viewing angle	250	400	-	-	Note 13-2
Response time	Rise	Tr	$\theta = 0^\circ$	-	10	15	ms	Note 13-3
	Fall	Tf		-	15	20	ms	
Brightness			$\theta = 0^\circ / \phi = 0$	400	500		cd/m ²	Note 13-4
Luminance Uniformity		U	$\theta = 0^\circ$	75	80	-	%	Note 13-5
LED Life Time				20000	-	-	hr	Note 13-8
White Chromaticity	x		$\theta = 0^\circ$	-	(0.31)	-	-	
	y		$\theta = 0^\circ$	-	(0.34)	-	-	
Cross Talk			$\theta = 0^\circ$	-	-	3.5	%	Note 13-6

Note 13-1 : The definitions of viewing angles are as follow

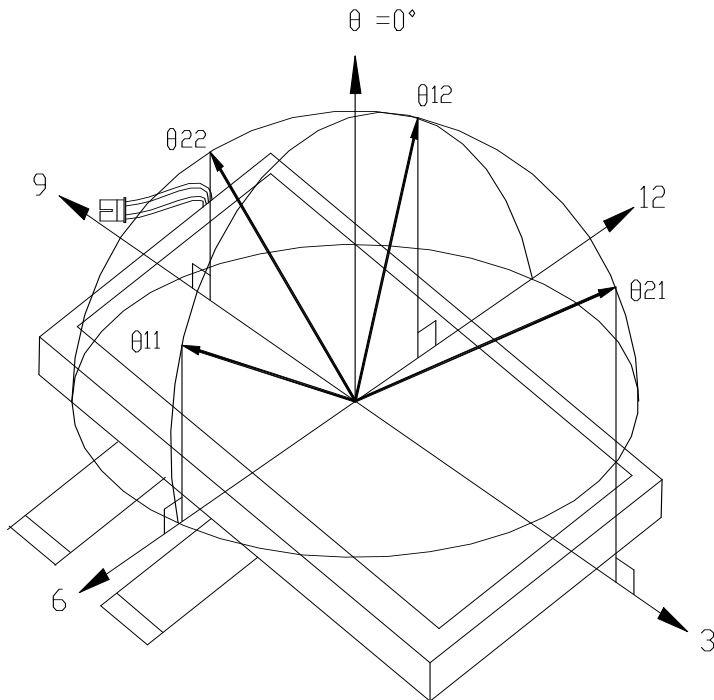

Note 13-2 : The definition of contrast ratio $CR = \frac{\text{Luminance at White Pattern}}{\text{Luminance at Black Pattern}}$

Note 13-3 : Definition of Response Time T_r and T_f :

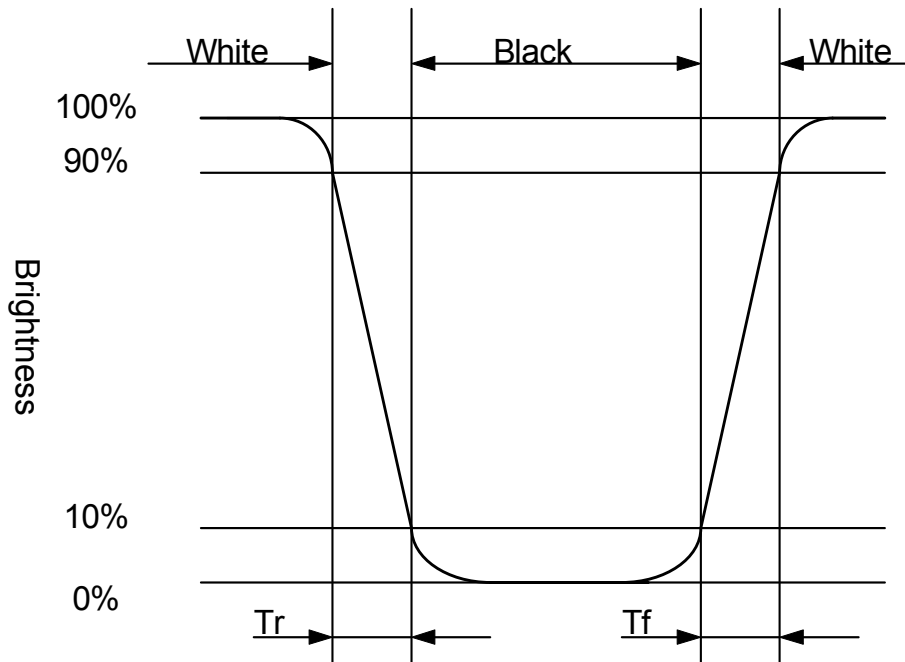

Note 13-4 : The optical characteristics shall be measured in dark room (ambient illumination on panel surface less than 1 Lux). The measuring configuration shows as following figure.

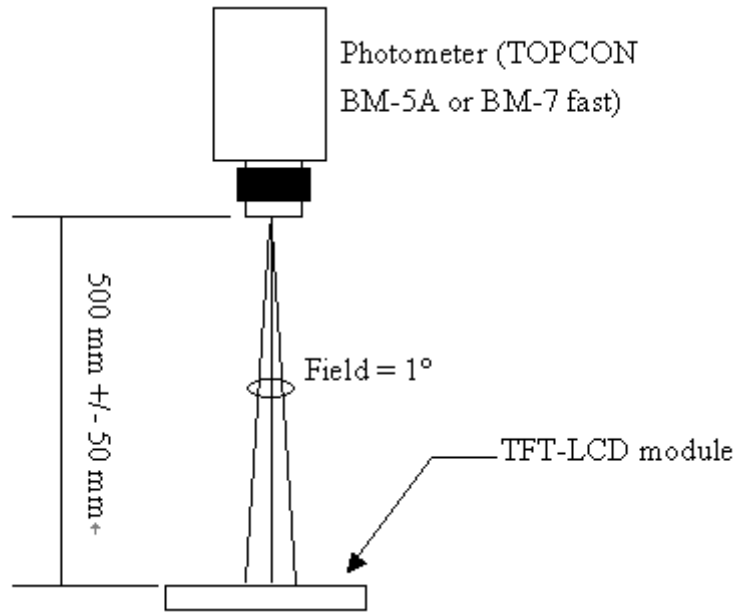

Optical characteristics measuring configuration

Note 13-5 : The uniformity of LCD is defined as :

$$U = \frac{\text{The Minimum Brightness of the 9 testing Points}}{\text{The Maximum Brightness of the 9 testing Points}}$$

Luminance meter : BM-5A or BM-7 fast (TOPCON)

Measurement distance : 500 mm +/- 50 mm

Ambient illumination < 1 Lux

Measuring direction : Perpendicular to the surface of module

The test pattern is white.

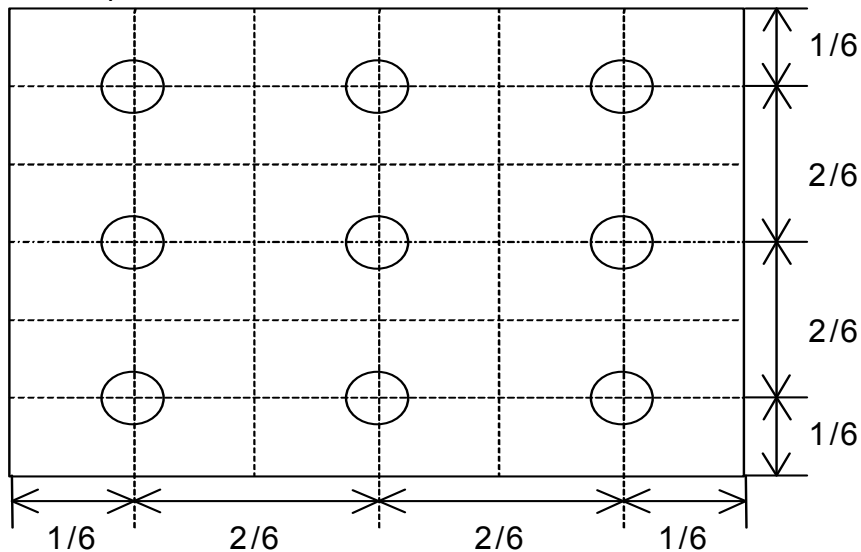

Note 13-6: Cross Talk (CTK) = $\frac{|YA-YB|}{YA} \times 100\%$

YA: Brightness of Pattern A

YB: Brightness of Pattern B

Luminance meter : BM 5A or BM-7 fast (TOPCON)

Measurement distance : 500 mm +/- 50 mm

Ambient illumination < 1 Lux

Measuring direction : Perpendicular to the surface of module

Pattern A
(Gray Level 31)

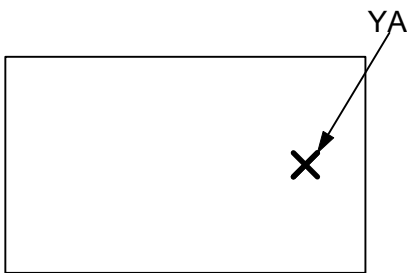

Pattern B
(Gray Level 31, central black box exclusive)

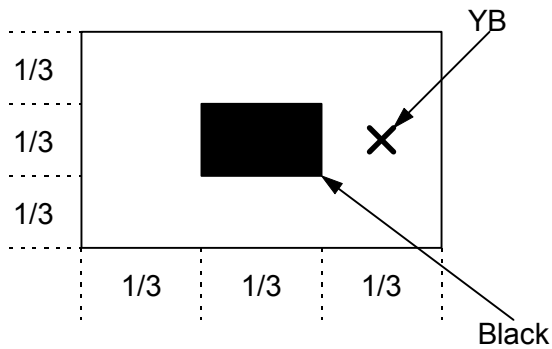

X: Measuring Point (A and B are at the same point.)

Black (Gray Level 0)

Note 13-7 : Topcon BM-7(fast)luminance meter 1° field of view is used in the testing.

Note 13-8 : The “LED Life time” is defined as the module brightness decrease to 50% original Brightness that the ambient temperature is 25°C and I_{LED} =150mA.

14. Handling Cautions :

14-1) Mounting of module :

- Please power off the module when you connect the input/output connector.
- Polarizer which is made of soft material and susceptible to flaw must be handled carefully.
- Protective film (Laminator) is applied on surface to protect it against scratches and dirt.
- Please following the tear off direction as figure14-1 to remove the protective film as slowly as possible, so that electrostatic charge can be minimized.

14-2) Precautions in mounting :

- When metal part of the TFT-LCD module (shielding lid and rear case) is soiled, wipe it with soft dry cloth.
- Wipe off water drops or finger grease immediately. Long contact with water may cause discoloration or spots.
- TFT-LCD module uses glass which breaks or cracks easily if dropped or bumped on hard surface. Please handle with care.
- Since CMOS LSI is used in the module. So take care of static electricity and earth yourself when handling.

14-3) Adjusting module :

- Adjusting volumes on the rear face of the module have been set optimally before shipment.
- Therefore, do not change any adjusted values. If adjusted values are changed, the specifications described may not be satisfied.

14-4) Others :

- Do not expose the module to direct sunlight or intensive ultraviolet rays for many hours.
- Store the module at a room temperature place.
- The voltage of beginning electric discharge may over the normal voltage because of leakage current from approach conductor by to draw lump read lead line around.
- If LCD panel breaks, it is possibly that the liquid crystal escapes from the panel. Avoid putting it into eyes or mouth. When liquid crystal sticks on hands, clothes or feet. Wash it out immediately with soap.
- Observe all other precautionary requirements in handling general electronic components.
- Please adjust the voltage of common electrode as material of attachment by 1 module.

14-5) Polarizer mark :

The polarizer mark is to describe the direction of wide view angle film how to mach up with the rubbing direction.

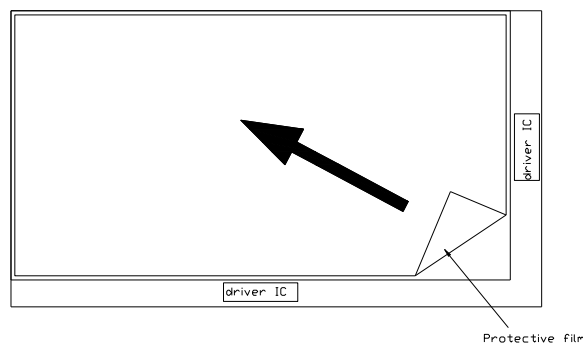

Figure 14-1 the way to peel off protective film

15. Reliability Test :

No	Test Item	Test Condition	Remark
1	High Temperature Storage Test	Ta = +95℃, 240 hrs	
2	Low Temperature Storage Test	Ta = -40℃, 240 hrs	
3	High Temperature Operation Test	Ta = +85℃, 240 hrs	
4	Low Temperature Operation Test	Ta = -30℃, 240 hrs	
5	High Temperature & High Humidity Operation Test	Ta = +60℃, 90%RH, 240 hrs (No Condensation)	
6	Thermal Cycling Test (non-operating)	-30℃ → +80℃, 200 Cycles 30min 30min	
7	Vibration Test (non-operating)	Frequency : 10 ~ 55 Hz, Amplitude : 1 mm Sweep time : 11 min Test Period : 6 Cycles for each direction of X, Y, Z	
8	Shock Test (non-operating)	100G, 6ms Direction: ±X, ±Y, ±Z Cycle: 3 times	
9	Electrostatic Discharge Test (non-operating)	200pF, 0Ω ±200V 1 time / each terminal	

Ta : ambient temperature

Note : The protective film must be removed before temperature test.

[Criteria]

There can be no display failures after exposure to reliability tests (including : line defect, no image).
All the cosmetic specification is judged before the reliability stress.

16. Packing :**TBD**